

Description

- 125°C maximum total temperature operation
- 3.1mm x 3.1mm x 1.2mm shielded drum core
- Ferrite core material
- Inductance range from 1.0uH to 220uH
- Current range from 1.65 Amps to 0.113 Amps
- Frequency range up to 4MHz



Applications

- Cellular phones, Digital cameras, CD players, PDA's
- Small LCD displays
- LED driver and LED flash circuits
- Hard disk drives
- Backlighting
- EL panel

Environmental Data

- Storage temperature range: -40°C to +125°C
- Operating temperature range: -40°C to +125°C (range is application specific)
- Solder reflow temperature: +260°C max. for 10 seconds maximum

Packaging

- Supplied in tape and reel packaging, 4100 per reel

Part Number	Rated Inductance (µH)	OCL (1) (µH)	Part Marking Designator	I _{rms} (2) Amperes	I _{sat} (3) Amperes	DCR (Ω) typ. @ 20°C	K-factor (4)
SD3112-1R0-R	1.0	1.11+/-30%	A	1.39	1.65	0.069	135
SD3112-1R5-R	1.5	1.70+/-30%	B	1.16	1.33	0.099	110
SD3112-2R2-R	2.2	2.41+/-30%	C	0.97	1.12	0.140	92
SD3112-3R3-R	3.3	3.24+/-30%	D	0.90	0.97	0.165	79
SD3112-4R7-R	4.7	4.72+/-30%	E	0.74	0.80	0.246	66
SD3112-6R8-R	6.8	6.47+/-30%	F	0.68	0.68	0.291	56
SD3112-8R2-R	8.2	8.50+/-30%	G	0.57	0.60	0.408	49
SD3112-100-R	10.0	10.01+/-30%	H	0.55	0.55	0.446	45
SD3112-150-R	15.0	15.28+/-20%	I	0.45	0.44	0.654	37
SD3112-220-R	22.0	21.66+/-20%	J	0.37	0.37	0.953	31
SD3112-330-R	33.0	33.30+/-20%	K	0.30	0.30	1.48	25
SD3112-470-R	47.0	47.44+/-20%	L	0.270	0.25	1.85	21
SD3112-680-R	68.0	68.10+/-20%	M	0.228	0.211	2.56	17
SD3112-820-R	82.0	83.19+/-20%	N	0.213	0.190	2.93	16
SD3112-101-R	100.0	99.8+/-20%	O	0.184	0.174	3.95	14
SD3112-151-R	150.0	149.4+/-20%	P	0.149	0.142	6.01	12
SD3112-221-R	220.0	219.9+/-20%	Q	0.121	0.117	9.12	10

(1) Open Circuit Inductance Test Parameters: 100kHz, 0.1V, 0.0Adc.

(2) I_{rms}: DC current for an approximate DT of 40°C without core loss. Derating is necessary for AC currents. PCB layout, trace thickness and width, air-flow, and proximity of other heat generating components will affect the temperature rise. It is recommended that the temperature of the part not exceed 125°C under worst case operating conditions verified in the end application.

(3) I_{sat} Amperes peak for approximately 30% rolloff (@20°C)

(4) K-factor: Used to determine B p-p for core loss (see graph).

B p-p = K*L*ΔI, B p-p(mT), K: (K factor from table), L: (Inductance in uH), ΔI (Peak to peak ripple current in Amps).

Mechanical Diagrams

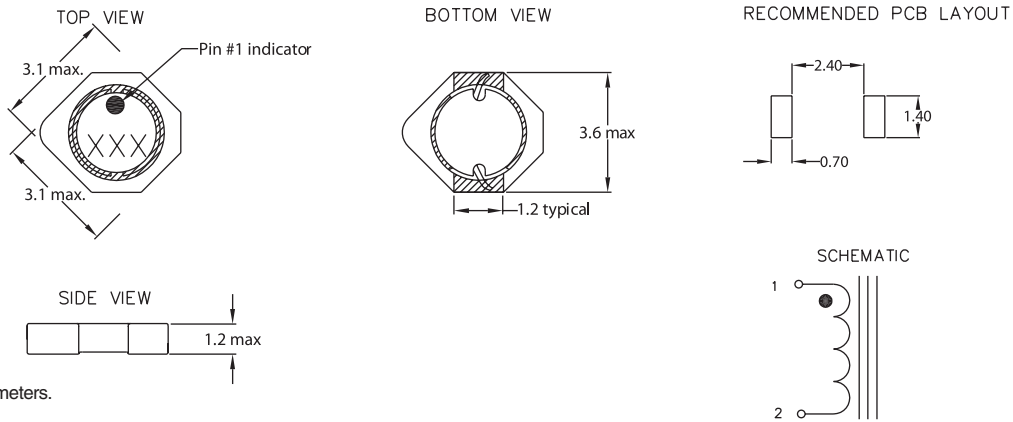

Dimensions are in millimeters.

Part Marking:
3 Digit Marking: (1st digit: Indicates inductance value per letter in Part Marking Designator); (2nd digit: Bi-weekly production date code); (3rd digit: Last digit of the year produced).

Packaging Information

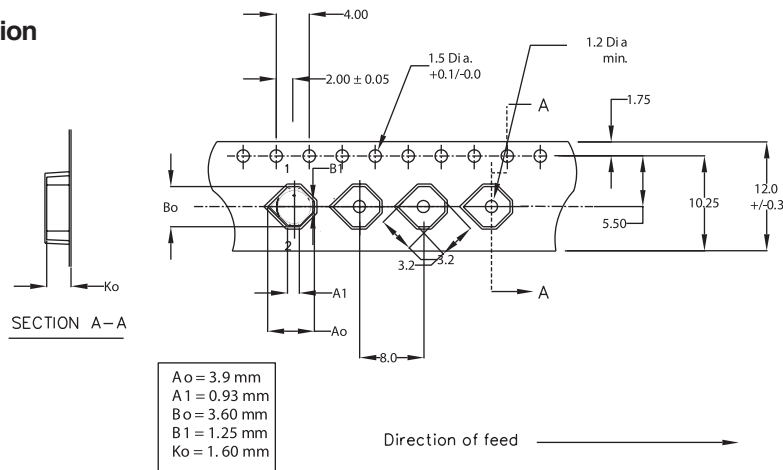

Parts packaged on 13" Diameter reel,
4,100 parts per reel.

DC Current vs. Temperature

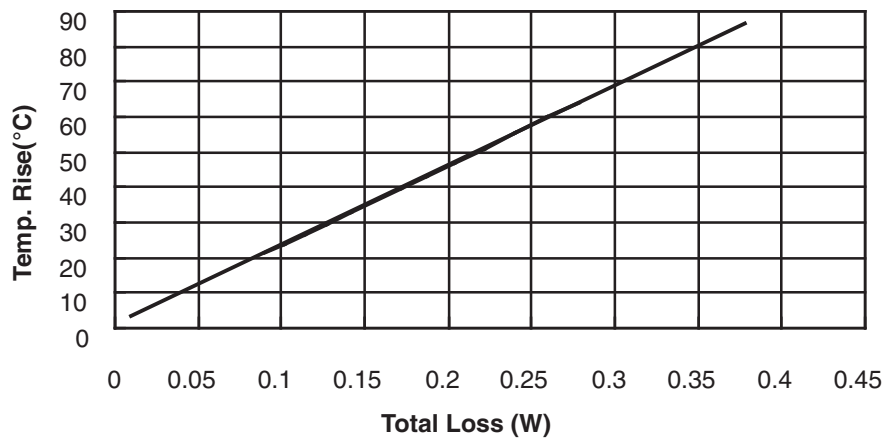

Core Loss

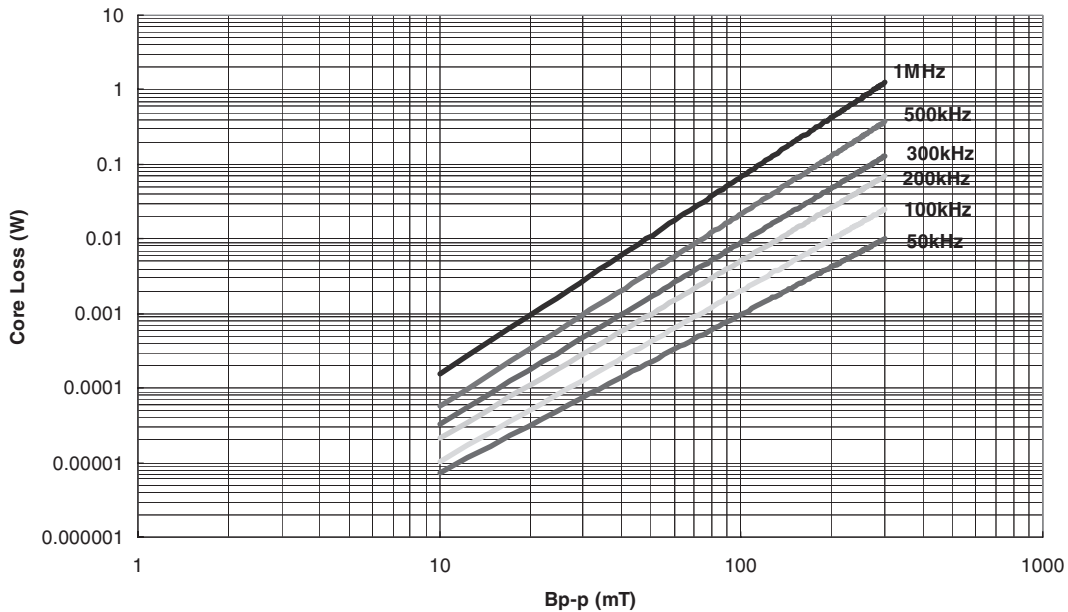

Inductance Characteristics

OCL vs Isat

