

CONTACT CONFIGURATION

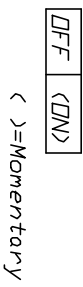

NOTES:

1. ALL DIMENSIONS IN MM [INCH]
2. GENERAL TOLERANCE: X.X=±0.4
X:XX=±0.25
3. TERM. NOS. FOR REF. ONLY
4. CONTACT RATING: 0.4VA @20VAC or DC max.
5. FIXED TERMINAL & MOVING CONTACT: Cu alloy w/Au plating OVER Nickel plating.
6. ELECTRICAL LIFE: 60,000 make-and-break cycle at full load.
7. DIELECTRIC STRENGTH: 1,000 V RMS @sea level.
8. OPERATING TEMP.: -30°C to 85°C

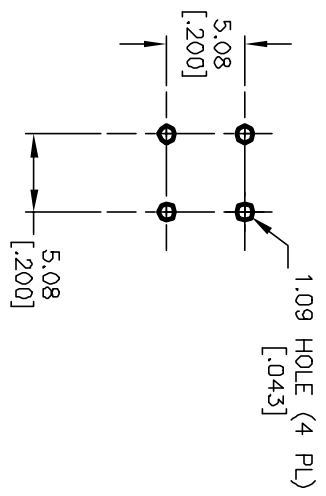

REV.	ECN No.	DESCRIPTION	DATE	CHKD
B	11870	REVISED AND REDRAWN	11/28/01	CJB

TITLE	SCALE	DATE	DR	DWG	REV
800 SP9 B7 M6 R E	2:1	11/28/01	CJB	T811005	B

E-SWITCH®

THE INFORMATION CONTAINED IN THIS DOCUMENT IS PROPRIETARY TO E-SWITCH AND IS NOT TO BE COPIED OR TRANSFERRED