

PRODUCT NUMBER
 XXXXX-YYY HTLF

- LEAD FREE OPTION (SEE NOTES 1)
- PACKAGING OPTIONS (SEE NOTE 1)
- HIGH TEMPERATURE PLASTIC (SEE NOTE 1)
- NO OF POSITIONS (SEE NOTE 1)
- PIN PLATING (SEE SHEET 2)
- BASE PART NO.

68000-X XX-XXX XXX LF

- TAIL LENGTH (EXAMPLE BELOW)
 3.0mm=030 12.8mm=128 (SEE NOTE 15 & 16)
- MATTING LENGTH (EXAMPLE BELOW)
 5.0mm=050 25.5mm=255 (SEE NOTE 15 & 16)
- TOTAL NUMBER OF POSITION FROM 1 THRU 36 POS. (SEE NOTE 1)
- PIN PLATING (SEE NOTE 13)
 1=0.76µm Au
 4= PURE TIN
 8=0.36µm Au
- BASE PART NO.

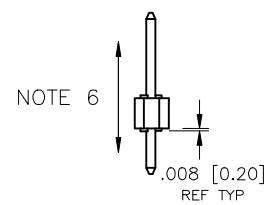
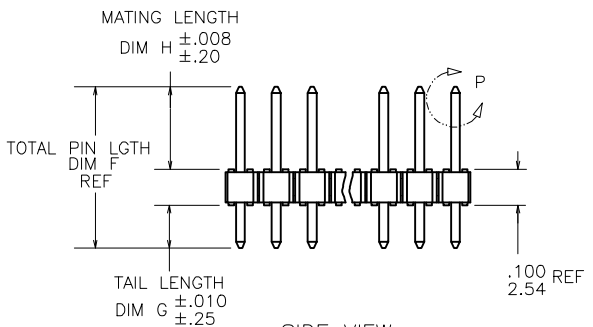
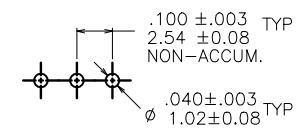
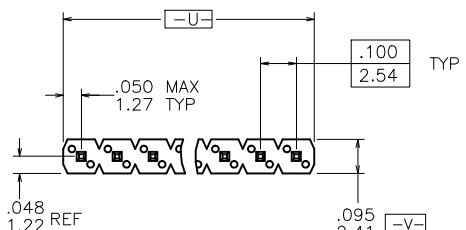

NOTE 4
 ⊕ ∅.020/.51 ⊕ U ⊕ V ⊕

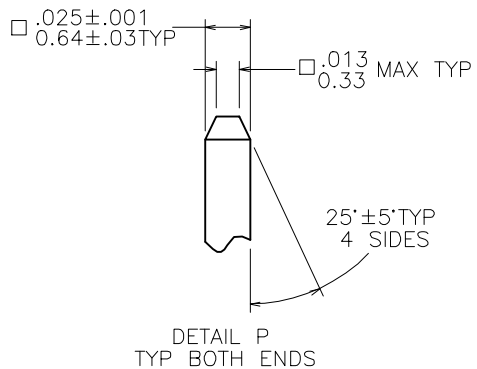

mat'l. code SEE NOTES 2 & 3				surface ISO 1302 ✓		tolerance ISO 406 ISO 1101		projection INCH/MM		product family BERGSTIK	
ltr	ecn no	dr	date	tolerances unless otherwise specified							
CL	M06-0039	MHT	1/18/06	angles	.XX±.01/XX±0.3		INCH/MM		title BERGSTIK® II HEADER		
CM	M06-0268	MHT	7/17/06	linear	.XXX±.006/XX±0.13		scale 1:1		.100/2.54cc SR STRAIGHT		
CN	M06-0348	MHT	9/04/06	0'±2'	.XXX±.0020/XXX±0.051				dwg no 68000		
CP	M07-0118	AGS	2/16/07	dr	T.BREWBAKER	01/05/95			sheet 1 of 8 size A3		
CR	M07-0150	AGS	3/06/07	engr	T.HANNA	01/05/95			type Product Customer Drawing		
CS	M08-0168	MHT	2/26/08	chr	J.MURPHY	01/05/95					
CT	M06-0265	MHT	9/23/08	appd	T.HANNA	01/05/95					
sheet	revision	CT	CT	CT	CT	CT	CT	CT	CT	CT	CT
index	sheet	1	2	3	4	5	6	7	8		



Copyright FCI

PIN PLATING CODES:	
XXXX-1YY	30u"/0.76u MIN (SEE NOTE 13) OVER 50u"/1.27u MIN Ni
XXXX-2YY	15u"/0.38u MIN (SEE NOTE 13) OVER 50u"/1.27u MIN Ni
XXXX-3YY	50u"/1.27u MIN Au OVER 50u"/1.27u MIN Ni
XXXX-4YY	100u"/2.54u MIN Sn OVER 50u"/1.27u MIN Ni (SEE NOTE 14)
XXXX-4YYHLF	
XXXX-5YY	15u"/0.38u MIN (SEE NOTE 13) OVER 50u"/1.27u MIN Ni
XXXX-6YY	30u"/0.76u MIN (SEE NOTE 13) OVER 50u"/1.27u MIN Ni
XXXX-7YY	30u"/0.76u MIN Au OVER 50u"/1.27u MIN Ni
XXXX-8YY	15u"/0.38u MIN Au OVER 50u"/1.27u MIN Ni
XXXX-9YY	15u"/0.38u MIN GXT OVER 50u"/1.27u MIN Ni
XXXX-0YY	30u"/0.76u MIN GXT OVER 50u"/1.27u MIN Ni

NOTES

1. PART NUMBER OPTIONS:

PIN PLATING CODES (SEE ABOVE)

HIGH TEMP. MATERIAL:

FOR HIGH-TEMPERATURE APPLICATIONS, SPECIFY AN "H" AT THE END OF THE PART NUMBER.

NUMBER OF POSITIONS :

ANY NUMBER OF POSITIONS FROM 1 THRU 36.
 -X00H INDICATES BERGSTRIIP PRODUCT. SEE PAGE 3 FOR SPECIAL GEOMETRY OF THIS CONTINUOUS STRIP PRODUCT.
 AUTOMATED REELS WILL CONTAIN 36,000 PINS.
 SEE SPECIFIC PART NUMBERS FOR AVAILABILITY.

PACKAGING :

NO INDICATOR IS STANDARD PACKAGING IN POLY BAGS.
 EIGHT DIGIT PART NUMBERS FOLLOWED BY A "T" ARE PACKAGED IN TUBES. SEE SPECIFIC PART NUMBERS FOR AVAILABILITY.
 EIGHT DIGIT PART NUMBERS FOLLOWED BY A "C" ARE PACKAGED IN TUBES WITH PICKUP CAP APPLIED. (NOT TOOLED)
 BERGSTRIIP™ PART NUMBERS FOLLOWED BY A "B" ARE BULK PRICED.

LEAD FREE :

ADD "HLF" SUFFIX AT THE END OF PART NUMBER FOR LEAD FREE OPTION, NOT AVAILABLE FOR -5YY, -5YYH, -6YY & -6YYH

2. BODY MATERIAL :

BERGSTIK: MANUFACTURER'S OPTION OF NYLON, PCT GLASS FIBER REINFORCED, OR LCP MINERAL FILLED FLAME RETARDANT PER UL-94V-0.
 COLOR : BLACK
 BERGSTRIIP™: PRODUCED WITH HIGH TEMPERATURE LCP THERMOPLASTIC, FLAME RETARDANT PER UL-94V-0.
 COLOR : BLACK
 PART NUMBERS WITH "H" SUFFIX WILL WITHSTAND EXPOSURE TO 260°C PEAK TEMPERATURE FOR 20 SECONDS IN WAVE SOLDER, INFRA-RED OR VAPOR PHASE SOLDER PROCESS.
 PART NUMBERS WITHOUT "H" SUFFIX WILL WITHSTAND EXPOSURE TO 260°C PEAK TEMPERATURE FOR WAVE SOLDER PROCESS.

3. PIN MATERIAL : PHOS-BRONZE.
4. MEASURED WITH PART IN RESTRAINED CONDITION.
5. TWO SIDES OF PIN TIPS NOT PLATED. TYPICAL BOTH ENDS.
6. 2LBS/0.9KG MIN PIN RETENTION IN EITHER DIRECTION.
7. PIN CANNOT PROTRUDE PAST EDGE OF HOUSING. MUST BE .005±.005/.13±.13 FROM END OF HOUSING HOLE.
8. MILITARY BERGSTIK HEADER
P/N XXXX-YYY-MIL.
NOT AVAILABLE.
9. ±.010/0.25 TOL APPLIES TO ALL "G" TAILS EXCEPT INDICATED PARTS ON TABLE WHERE +.010/0.25 -.000/0.00 APPLIES.
10. INDICATED PART NUMBERS ARE PRODUCED AND SOLD IN THE TAIWAN/SINGAPORE AREAS. THESE ARE NOT AVAILABLE IN BERGSTRIIP™ CONTINUOUS STRIP.
11. NOTCH CONFIGURATION WILL VARY PER VENDOR'S DISCRETION.
12. THESE PRODUCTS MEETS EUROPEAN UNION DIRECTIVES AND OTHER COUNTRY REGULATION AS DESCRIBED IN GS-22-008.
13. PLATING OPTIONS:
MAY BE EITHER GOLD OR GXT PLATED AT MANUFACTURER'S OPTION.
14. "THIS PRODUCT HAS 100% TIN PLATING IN THE INTERFACE AND HAS NOT BEEN TESTED FOR WHISKER GROWTH IN ALL INTERCONNECT ENVIRONMENTS."
15. THE OAL DON'T EXCEED 34.5mm
16. INCREMENTS BY 0.1mm IN LENGTHS ONLY
17. FOR SPECIAL PACKAGING REQUEST PLEASE CONTACT PRODUCT MANAGER FOR AVAILABILITY

mat'l. code SEE NOTES 2 & 3		surface ISO 1302	tolerance ISO 406 ISO 1101	projection 	product family BERGSTIK
ltr	ecn no	dr	date	tolerances unless otherwise specified	title BERGSTIK II HEADER
CT				angles linear XX±.01/XX±0.3 XXX±.006/XXX±0.13 O'±2' XXXX±.0020/XXXX±0.051	INCH/MM scale 1:1
				dr T.BREWBAKER 01/05/95	dwg no 68000
				engr T.HANNA 01/05/95	sheet 2 of 8 size A3
				chr J.MURPHY 01/05/95	type Product Customer Drawing
				appd T.HANNA 01/05/95	
sheet	revision				
index	sheet				



Copyright FCI

BERGSTRIPTM HEADER

REEL PACKING DIMENSIONS

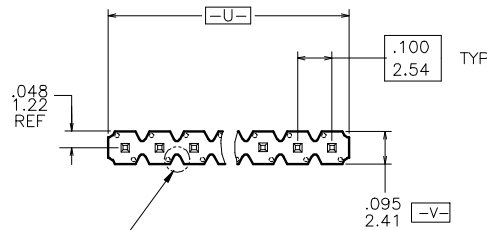

SINGLE ROW TOP VIEW

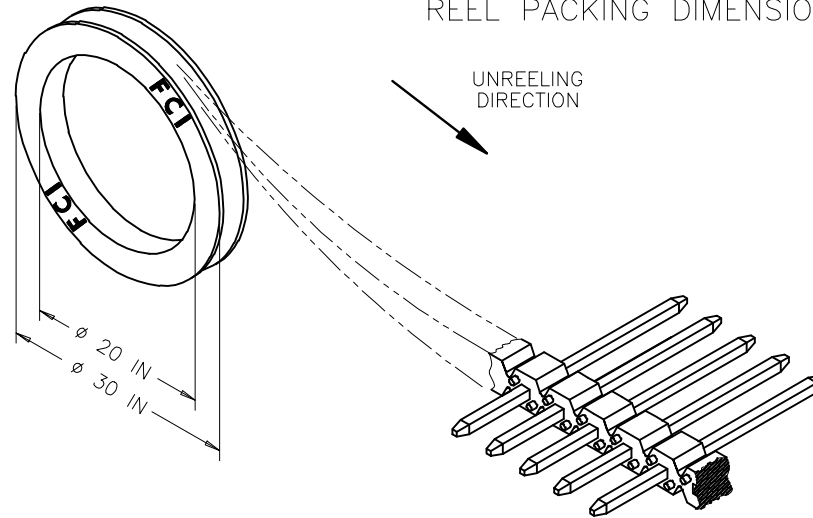

UNREELING DIRECTION

NOTE 11

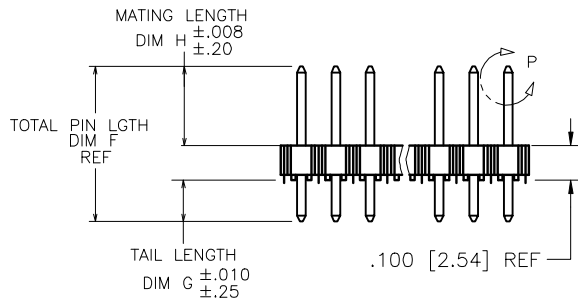

SINGLE ROW SIDE VIEW

NOTE 6

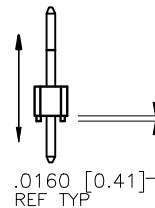

SINGLE ROW END VIEW



Copyright FCJ

mat'l code SEE NOTES 2 & 3		surface ISO 1302	tolerance ISO 406 ISO 1101	projection 	product family BERGSTIK
ltr	ecn no	dr	date	tolerances unless otherwise specified	title
CT				angles linear XX±.01/XX±0.3 XXX±.005/XXX±0.13 0°±2' XXXX±.0020/XXX±0.051	INCH/MM BERGSTIK® II HEADER .100/2.54cc SR STRAIGHT
		dr	T.BREWBAKER	01/05/95	dwg no sheet 3 of 8 size
		enr	T.HANNA	01/05/95	68000 A3
		chr	J.MURPHY	01/05/95	type Product Customer Drawing
		appd	T.HANNA	01/05/95	
sheet index	revision sheet				

PRODUCT NUMBER	TOTAL PIN LGTH		TAIL LENGTH		MATING LENGTH		PACKAGING	NOTES	BERGSTRIK™	LF OPTION
	DIM F	DIM F	DIM G	DIM G	DIM H	DIM H			AVAILABLE	
	ENGLISH	METRIC	ENGLISH	METRIC	ENGLISH	METRIC				
55492-XXYH	0.315	8.00	0.095	2.41	0.120	3.05	POLY BAGS	-	NO	NOTE 1,12
60017-XXYH	0.620	15.75	0.210	5.33	0.310	7.87	POLY BAGS	-	NO	
60018-XXYH	0.660	16.76	0.250	6.35	0.310	7.87	POLY BAGS	-	NO	
63334-XXYH	0.435	11.05	0.095	2.41	0.240	6.10	POLY BAGS	-	NO	
68000-XXX	0.425	10.80	0.095	2.41	0.230	5.84	POLY BAGS	-	YES	
68001-XXX	0.450	11.43	0.120	3.05	0.230	5.84	POLY BAGS/TUBES	-	YES	
68002-XXX	0.480	12.19	0.150	3.81	0.230	5.84	POLY BAGS	-	YES	
68003-XXX	0.525	13.34	0.195	4.95	0.230	5.84	POLY BAGS	-	NO	
68004-XXX	0.525	13.34	0.107	2.72	0.318	8.08	POLY BAGS	-	YES	
68024-XXX	0.568	14.43	0.150	3.81	0.318	8.08	POLY BAGS	-	YES	
68031-XXX	0.513	13.03	0.183	4.65	0.230	5.84	POLY BAGS	-	NO	
68032-XXX	0.543	13.79	0.213	5.41	0.230	5.84	POLY BAGS	-	NO	
68033-XXX	0.708	17.98	0.473	12.01	0.135	3.43	POLY BAGS	-	NO	
68415-XXX	0.615	15.62	0.115	2.92	0.400	10.16	POLY BAGS	-	NO	
68416-XXX	0.813	20.65	0.483	12.27	0.230	5.84	POLY BAGS	-	NO	
68418-XXX	0.730	18.54	0.400	10.16	0.230	5.84	POLY BAGS	-	NO	
68422-XXX	0.631	16.03	0.213	5.41	0.318	8.08	POLY BAGS	-	NO	
68443-XXX	0.755	19.18	0.425	10.80	0.230	5.84	POLY BAGS	-	NO	
68456-XXX	0.825	20.96	0.115	2.92	0.610	15.49	POLY BAGS	-	NO	
68457-XXX	0.548	13.92	0.130	3.30	0.318	8.08	POLY BAGS	-	NO	
68465-XXX	0.925	23.50	0.595	15.11	0.230	5.84	POLY BAGS	-	NO	
68466-XXX	0.925	23.50	0.128	3.25	0.697	17.70	POLY BAGS	-	NO	
68472-XXX	0.913	23.19	0.413	10.49	0.400	10.16	POLY BAGS	-	NO	
68479-XXX	0.718	18.24	0.388	9.86	0.230	5.84	POLY BAGS	-	NO	
68483-XXX	0.835	21.21	0.417	10.59	0.318	8.08	POLY BAGS	-	NO	
68487-XXX	0.705	17.91	0.110	2.79	0.495	12.57	POLY BAGS	-	NO	
68489-XXX	1.095	27.81	0.765	19.43	0.230	5.84	POLY BAGS	-	NO	
68490-XXX	1.025	26.04	0.695	17.65	0.230	5.84	POLY BAGS	-	NO	
68497-XXX	0.612	15.54	0.085	2.16	0.427	10.85	POLY BAGS	-	NO	
68603-XXX	0.555	14.10	0.120	3.05	0.335	8.51	POLY BAGS	-	NO	
68604-XXX	0.600	15.24	0.120	3.05	0.380	9.65	POLY BAGS	-	NO	



FCConnect.com

Copyright FCJ

mat'l code SEE NOTES 2 & 3		surface ISO 1302	tolerance ISO 406 ISO 1101	projection 	product family BERGSTIK
ltr	ecn no	dr	date	title BERGSTIK® II HEADER	
CT				.100/2.54cc SR STRAIGHT	
				INCH/MM	scale 1:1
				dwg no 68000 sheet 4 of 8 size A3	
				type Product Customer Drawing	
dr	T.BREWBAKER	01/05/95			
enr	T.HANNA	01/05/95			
chr	J.MURPHY	01/05/95			
appd	T.HANNA	01/05/95			
sheet index	revision sheet				

PRODUCT NUMBER	TOTAL PIN LGTH		TAIL LENGTH		MATING LENGTH		PACKAGING	NOTES	BERGSTRIIP™ AVAILABLE
	DIM F	DIM F	DIM G	DIM G	DIM H	DIM H			
	ENGLISH	METRIC	ENGLISH	METRIC	ENGLISH	METRIC			
68629-YYY	0.621	15.77	0.203	5.16	0.318	8.08	POLY BAGS	-	NO
68630-YYY	0.603	15.32	0.273	6.93	0.230	5.84	POLY BAGS	-	NO
68631-YYY	0.703	17.86	0.203	5.16	0.400	10.16	POLY BAGS	-	NO
68632-YYY	0.743	18.87	0.413	10.49	0.230	5.84	POLY BAGS	-	NO
68633-YYY	0.643	16.33	0.225	5.72	0.318	8.08	POLY BAGS	-	NO
68634-YYY	1.013	25.73	0.683	17.35	0.230	5.84	POLY BAGS	-	NO
68642-YYY	0.913	23.19	0.583	14.81	0.230	5.84	POLY BAGS	-	NO
68652-YYY	1.470	37.34	0.670	17.02	0.700	17.78	POLY BAGS	-	NO
68653-YYY	0.735	18.67	0.095	2.41	0.540	13.72	POLY BAGS	-	NO
68654-YYY	1.050	26.67	0.670	17.02	0.280	7.11	POLY BAGS	-	NO
68655-YYY	0.708	17.98	0.290	7.37	0.318	8.08	POLY BAGS	-	NO
68656-YYY	1.113	28.27	0.613	15.57	0.400	10.16	POLY BAGS	-	NO
68657-YYY	0.588	14.94	0.368	9.35	0.120	3.05	POLY BAGS	-	NO
68658-YYY	0.820	20.83	0.130	3.30	0.590	14.99	POLY BAGS	-	NO
68659-YYY	0.608	15.44	0.398	10.11	0.110	2.79	POLY BAGS	-	NO
68686-YYY	1.016	25.81	0.458	11.63	0.458	11.63	POLY BAGS	-	NO
68689-YYY	0.913	23.19	0.213	5.41	0.600	15.24	POLY BAGS	-	NO
68705-YYY	0.395	10.03	0.095	2.41	0.200	5.08	POLY BAGS	-	NO
68717-YYY	0.615	15.62	0.285	7.24	0.230	5.84	POLY BAGS	-	NO
68730-YYY	0.555	14.10	0.225	5.72	0.230	5.84	POLY BAGS	-	NO
68731-YYY	0.880	22.35	0.440	11.18	0.340	8.64	POLY BAGS	-	NO
68735-YYY	1.016	25.81	0.520	13.21	0.396	10.06	POLY BAGS	-	NO
68755-YYY	1.166	29.62	0.533	13.54	0.533	13.54	POLY BAGS	-	NO
68760-YYY	0.803	20.40	0.353	8.97	0.350	8.89	POLY BAGS	-	NO
68762-YYY	0.588	14.94	0.213	5.41	0.275	6.99	POLY BAGS	-	NO
68771-YYY	0.470	11.94	0.100	2.54	0.270	6.86	POLY BAGS	-	NO
68781-YYY	0.691	17.55	0.273	6.93	0.318	8.08	POLY BAGS	-	NO

LF OPTION
NOTE 1,12



FCconnect.com

Copyright FCJ

mat'l. code SEE NOTES 2 & 3				surface ISO 1302	tolerance ISO 406 ISO 1101	projection 	product family BERGSTIK
ltr	ecn no	dr	date	tolerances unless otherwise specified		INCH/MM 	title BERGSTIK® II HEADER .100/2.54cc SR STRAIGHT
CT				angles	linear		
				0° ±2'	.XX±.01/XX±0.3 .XXX±.006/XX±0.13 .XXX±.0020/XXX±0.051	scale 1:1	dwg no 68000
				dr	T.BREWBAKER 01/05/95		sheet 5 of 8 size A3
				engr	T.HANNA 01/05/95		type Product Customer Drawing
				chr	J.MURPHY 01/05/95		
				appd	T.HANNA 01/05/95		
sheet index	revision sheet						

PRODUCT NUMBER	TOTAL PIN LGTH		TAIL LENGTH		MATING LENGTH		PACKAGING	NOTES	BERGSTRIPTM AVAILABLE	LF OPTION
	DIM F	DIM F	DIM G	DIM G	DIM H	DIM H				
	ENGLISH	METRIC	ENGLISH	METRIC	ENGLISH	METRIC				
68795-YYY	0.500	12.70	0.062	1.57	0.338	8.59	POLY BAGS	-	NO	NOTE 1,12
68796-YYY	0.633	16.08	0.423	10.74	0.110	2.79	POLY BAGS	-	NO	
68797-YYY	0.413	10.49	0.213	5.41	0.100	2.54	POLY BAGS	-	NO	
69148-YYY	0.442	11.43	0.000	0.00	0.350	8.89	POLY BAGS	-	NO	
69152-YYY	0.720	18.29	0.120	3.05	0.500	12.70	POLY BAGS/TUBES	-	NO	
69173-YYY	0.530	13.46	0.135	3.43	0.295	7.49	POLY BAGS	-	NO	
69188-YYY	0.751	19.08	0.333	8.46	0.318	8.08	POLY BAGS	-	NO	
69751-YYY	0.440	11.18	0.170	4.32	0.170	4.32	POLY BAGS	NOTE 10	NO	
71417-YYY	0.664	16.87	0.115	2.92	0.449	11.40	POLY BAGS	NOTE 10	NO	
72260-XXYH	0.930	23.62	0.090	2.29	0.740	18.80	POLY BAGS	-	NO	
72323-XXYH	1.200	30.48	0.100	2.54	1.000	25.40	POLY BAGS	-	NO	
72457-XXYH	1.100	27.94	0.090	2.29	0.910	23.11	POLY BAGS	-	NO	
73698-XXYH	1.100	27.94	0.120	3.05	0.880	22.35	POLY BAGS	-	NO	
74464-XXYH	1.028	26.11	0.610	15.49	0.318	8.08	POLY BAGS	-	NO	
78240-YYY	0.663	16.84	0.333	8.46	0.230	5.84	POLY BAGS	-	NO	
78287-YYY	0.678	17.22	0.120	3.05	0.458	11.63	POLY BAGS	-	NO	
78290-YYY	1.250	31.75	0.500	12.70	0.650	16.51	POLY BAGS	-	NO	
78511-YYY	0.538	13.67	0.120	3.05	0.318	8.08	POLY BAGS/TUBES	-	YES	
78595-YYY		NOT AVAILABLE						-	-	
78931-YYY		NOT AVAILABLE						-	-	
78958-YYY		NOT AVAILABLE						-	-	
78959-YYY		NOT AVAILABLE						-	-	
78977-YYY		NOT AVAILABLE						-	-	
78998-YYY	0.430	10.92	0.155	3.94	0.175	4.45	POLY BAGS	-	NO	
78999-YYY		NOT AVAILABLE						-	-	
79428-YYY	0.695	17.65	0.120	3.05	0.475	12.07	POLY BAGS	-	NO	
79849-YYY	0.620	15.75	0.120	3.05	0.400	10.16	POLY BAGS	-	NO	



Copyright FCJ

mat'l. code SEE NOTES 2 & 3		surface ISO 1302	tolerance ISO 1101	projection	product family BERGSTIK
ltr	ecp no	dr	date	INCH/MM	title BERGSTIK® II HEADER
CT				linear	.100/2.54cc SR STRAIGHT
				0'±2'	scale 1:1
				dr	T.BREWBAKER 01/05/95
				engr	T.HANNA 01/05/95
				chr	J.MURPHY 01/05/95
				appd	T.HANNA 01/05/95
sheet	revision				type Product Customer Drawing
index	sheet				

PRODUCT NUMBER	TOTAL PIN LGTH		TAIL LENGTH		MATING LENGTH		PACKAGING	NOTES	BERGSTRIPTM AVAILABLE
	DIM F	DIM F	DIM G	DIM G	DIM H	DIM H			
	ENGLISH	METRIC	ENGLISH	METRIC	ENGLISH	METRIC			
84918-XYH	0.340	8.64	0.120	3.05	0.120	3.05	POLY BAGS	--	YES
84921-XYH	0.370	9.40	0.150	3.81	0.120	3.05	POLY BAGS	--	YES
86506-XYH	0.440	11.18	0.120	3.05	0.220	5.59	POLY BAGS	--	YES
86579-XYH	0.450	11.43	0.120	3.05	0.230	5.84	POLY BAGS	NOTE 9	NO
86634-XYH		NOT AVAILABLE						--	--
86635-XYH		NOT AVAILABLE						--	--
86636-XYH		NOT AVAILABLE						--	--
86637-XYH		NOT AVAILABLE						--	--
86638-XYH		NOT AVAILABLE						--	--
86793-XYH	0.900	22.86	0.100	2.54	0.700	17.78	POLY BAGS	NOTE 10	NO
86899-XYH	1.020	25.91	0.120	3.05	0.800	20.32	POLY BAGS	--	NO
87185-XYH	1.238	31.45	0.095	2.41	1.043	26.49	POLY BAGS	NOTE 10	NO
87204-XYH	0.895	22.73	0.120	3.05	0.675	17.15	POLY BAGS	--	NO
87241-XYH	1.000	25.40	0.120	3.05	0.780	19.81	POLY BAGS	--	NO
87502-XYH	1.130	28.70	0.110	2.79	0.920	23.37	POLY BAGS	--	NO
87827-XYH	0.380	9.65	0.120	3.05	0.160	4.06	POLY BAGS	--	NO
87916-XYH	1.058	26.87	0.128	3.25	0.830	21.08	POLY BAGS	--	NO
88005-XYH	0.536	13.61	0.095	2.41	0.341	8.66	POLY BAGS	NOTE 10	NO
88706-XYH	0.900	22.86	0.100	2.54	0.700	17.78	POLY BAGS	--	NO
89232-XYH	0.325	8.26	0.000	0.00	0.230	5.84	POLY BAGS	NOTE 7	NO

LF
OPTION

NOTE 1,12

NOTE 1,12



FCconnect.com

Copyright FCJ

mat'l. code SEE NOTES 2 & 3		surface ISO 1302	tolerance ISO 406 ISO 1301	projection 	product family BERGSTIK
ltr	ecn no	dr	date	tolerances unless otherwise specified	title BERGSTIK® II HEADER
CT				linear XX±.01/XX±0.3 XXX±.006/XXX±0.13 XXXX±.0020/XXXX±0.051	.100/2.54cc SR STRAIGHT
				INCH/MM scale 1:1	dwg no 68000
		dr	T.BREWBAKER	01/05/95	sheet 7 of 8 size A3
		engr	T.HANNA	01/05/95	type Product Customer Drawing
		chr	J.MURPHY	01/05/95	
		appd	T.HANNA	01/05/95	
sheet index	revision sheet				

form: A3

PRODUCT NUMBER	TOTAL PIN LGTH		TAIL LENGTH		MATING LENGTH		PACKAGING	NOTES	BERGSTRIPTM AVAILABLE	LF OPTION
	DIM F	DIM F	DIM G	DIM G	DIM H	DIM H				
	ENGLISH	METRIC	ENGLISH	METRIC	ENGLISH	METRIC				
90522-XYX	0.668	16.97	0.135	3.43	0.433	11.00	POLY BAGS	NOTE 10	NO	NOTE 1,12
90547-XYX	0.508	12.90	0.095	2.41	0.313	7.95	POLY BAGS	NOTE 10	NO	
90719-XYX	0.384	9.75	0.106	2.69	0.178	4.52	POLY BAGS	-	NO	
90726-XYX	0.440	11.18	0.110	2.79	0.230	5.84	POLY BAGS	-	YES	
91276-XYX	1.225	31.12	0.225	5.72	0.900	22.86	POLY BAGS	-	NO	
92020-XYX	0.372	9.45	0.094	2.39	0.178	4.52	POLY BAGS	-	NO	
92418-XYX	0.572	14.53	0.118	3.00	0.354	8.99	POLY BAGS	-	NO	
93167-XYX	0.394	10.01	0.059	1.50	0.235	5.97	POLY BAGS	-	NO	
93287-XYXH	0.585	14.86	0.085	2.16	0.400	10.16	POLY BAGS	-	NO	
93944-XYX	0.941	23.90	0.130	3.30	0.711	18.06	POLY BAGS	-	NO	
93992-XYXH	0.415	10.54	0.085	2.16	0.230	5.84	POLY BAGS	-	NO	
94063-XYX	0.376	9.55	0.138	3.51	0.138	3.51	POLY BAGS	NOTE 10	NO	
94094-XYX	0.592	15.04	0.314	7.98	0.178	4.52	POLY BAGS	-	NO	
94544-XYX	0.550	13.97	0.130	3.30	0.330	8.38	POLY BAGS	NOTE 10	NO	
94611-XYXH	0.320	8.13	0.095	2.41	0.125	3.18	POLY BAGS	-	NO	
95017-XYXH	0.560	14.22	0.060	1.52	0.400	10.16	POLY BAGS	-	NO	
95103-XYX	1.064	27.03	0.433	11.00	0.531	13.49	POLY BAGS	NOTE 10	NO	
95104-XYX	0.370	9.40	0.126	3.20	0.144	3.66	POLY BAGS	NOTE 10	NO	
95648-XYXH	0.655	16.64	0.155	3.94	0.400	10.16	POLY BAGS	-	NO	
95655-XYX	1.164	29.57	0.095	2.41	0.969	24.61	POLY BAGS	NOTE 10	NO	
98001-XYXH	0.610	15.49	0.420	10.67	0.090	2.29	POLY BAGS	-	NO	
98136-XYXH	0.475	12.07	0.095	2.41	0.280	7.11	POLY BAGS	-	NO	
10004394-XYXH	0.290	7.37	0.095	2.41	0.095	2.41	POLY BAGS	-	NO	
10076764-XYXH	0.479	12.19	0.114	2.9	0.265	6.75	POLY BAGS	-	YES	



FCconnect.com

Copyright FCJ

mat'l. code SEE NOTES 2 & 3				surface ISO 1302	tolerance ISO 406 ISO 1101	projection 	product family BERGSTIK
ltr	ecn no	dr	date	tolerances unless otherwise specified		INCH/MM 	title BERGSTIK® II HEADER .100/2.54cc SR STRAIGHT
CT				angles	linear		
				0° ±2'	XXX±.01/XX±0.3 XXX±.006/XX±0.13 XXX±.0020/XXX±0.051	scale 1:1	dwg no 68000
		dr	T.BREWBAKER	01/05/95			sheet 8 of 8 size A3
		engr	T.HANNA	01/05/95			type Product Customer Drawing
		chr	J.MURPHY	01/05/95			
		appd	T.HANNA	01/05/95			
sheet index	revision sheet						