

1487 Series Pull Through Wireway - NEMA 12



Wireway & Trough

Application

- Designed to enclose and protect electrical wiring from dirt, dust, oil and water.
- Ideal for connecting machines to control panels or power sources.

Standards

- UL 870 Type 1 (unless marked¹)
- CSA Type 1 (unless marked¹)
- **Complies with**
 - NEMA Type 12
 - JIC EMP-1-1967
 - JIC EGP-1-1967
 - IEC 60529, IP54

Construction

- Bodies and covers are formed from 14 gauge steel with 10 gauge steel flanges.
- Smooth continuously welded seams.
- Interior surfaces are smooth to prevent wire damage during installation.
- Butt hinged covers are secured with easily operated screw clamps.
- Oil resistant gaskets are permanently secured.
- Solid oil resistant gaskets are used between flanges when sections and fittings are bolted together.
- One gasket kit, complete with hardware is provided with each straight section or fitting.

Finish

- Sections and fittings are finished in ANSI 61 gray.

Pull Through Wireway

1487 Series Pull Through Wireway - NEMA 12

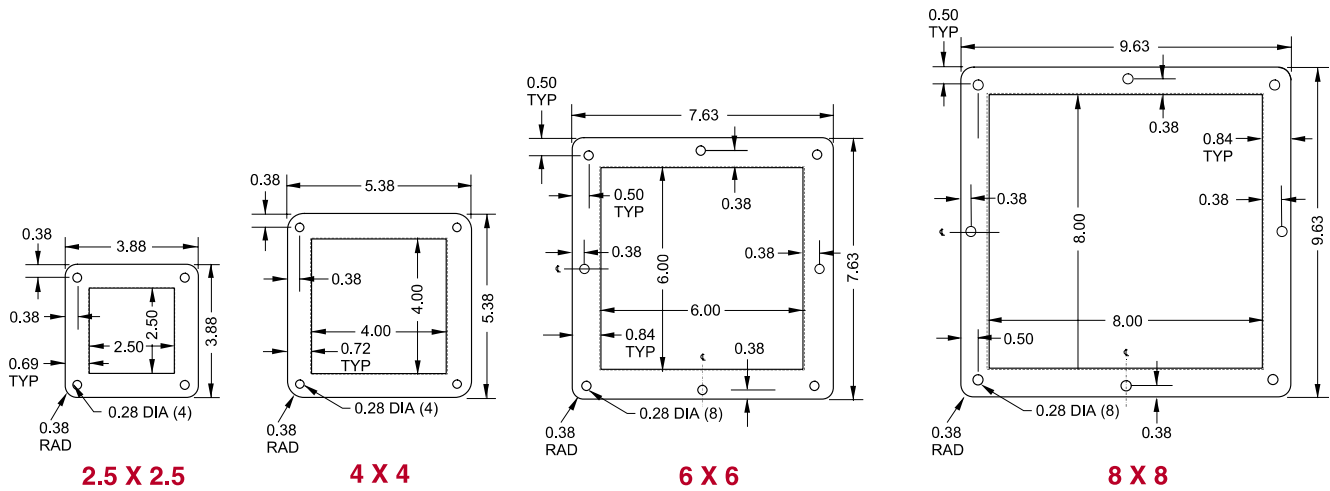

Wireway & Trough

Pull Through Wireway

Description	2.5 x 2.5 Part No.	4 x 4 Part No.	6 x 6 Part No.	8 x 8 Part No.
12" Section	1487B12	1487C12	1487D12	1487E12
24" Section	1487B24	1487C24	1487D24	1487E24
36" Section	1487B36	1487C36	1487D36	1487E36
48" Section	1487B48	1487C48	1487D48	1487E48
60" Section	1487B60	1487C60	1487D60	1487E60
120" Section	1487B120	1487C120	1487D120	1487E120
60" Long Partition (Barrier)	—	1487CB60 ¹	1487DB60 ¹	1487EB60 ¹
1" Nipple	1487BM1	1487CM1	1487DM1	1487EM1
2" Nipple	1487BM2	1487CM2	1487DM2	1487EM2
3" Nipple	1487BM3	1487CM3	1487DM3	1487EM3
6" Nipple	1487BM6	1487CM6	1487DM6	1487EM6
Box Entry Swivel Nipple	1487BV1	1487CV1	1487DV1	1487EV1
Standard Swivel Nipple	1487BV2	1487CV2	1487DV2	1487EV2
Flexible Fitting	1485BFF ¹	1485CFF ¹	1485DFF ¹	1485EFF ¹
Adjustable Fitting	1487BX ¹	1487CX ¹	1487DX ¹	1487EX ¹
Cut-Off Fitting	1487BW ¹	1487CW ¹	1487DW ¹	1487EW ¹
90° Elbow	1487B9P	1487C9P	1487D9P	1487E9P
45° Elbow	1487B4P	1487C4P	1487D4P	1487E4P
22.5° Elbow	1487B2P	1487C2P	1487D2P	1487E2P
Tee Fitting	1487BT	1487CT	1487DT	1487ET
Cross Fitting	1487BY	1487CY	1487DY	1487EY
Center Hole Reducers				
Reducer - 4 x 4 to 2.5 x 2.5	—	1487CRC ²	—	—
Reducer - 6 x 6 to 4 x 4	—	—	1487DRC ²	—
Reducer - 8 x 8 to 4 x 4	—	—	—	1487ERCC ²
Reducer - 8 x 8 to 6 x 6	—	—	—	1487ERCD ²
Edge Hole Reducers				
Reducer 4 x 4 to 2.5 x 2.5	—	1487CRE ²	—	—
Reducer 6 x 6 to 4 x 4	—	—	1487DRE ²	—
Reducer 8 x 8 to 4 x 4	—	—	—	1487EREC ²
Reducer 8 x 8 to 6 x 6	—	—	—	1487ERED ²
Box Connector	1487BK ¹	1487CK ¹	1487DK ¹	1487EK ¹
Drop Hanger	1485BL1 ¹	1485CL1 ¹	1485DL1 ¹	1485EL1 ¹
Bracket Hanger	1485BL2 ¹	1485CL2 ¹	1485DL2 ¹	1485EL2 ¹
Cover Plate	1487BH ²	1487CH ²	1487DH ²	1487EH ²
Gasket & Screws	1487BS ¹	1487CS ¹	1487DS ¹	1487ES ¹

¹ Does not meet CSA or UL requirements

² Maintains ratings on CSA and UL approved wireway

1487 Series Pull Through Wireway - NEMA 12

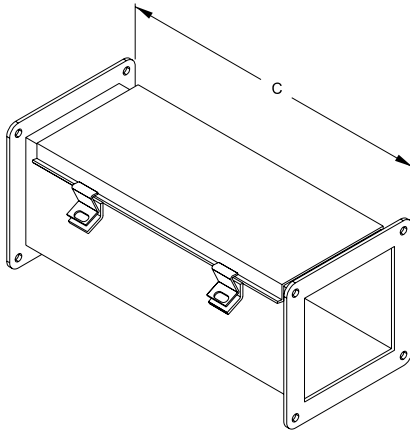

Typical Straight Section

C=12" Section Part No.	C=24" Section Part No.	C=36" Section Part No.	C=48" Section Part No.	C=60" Section Part No.	C=120" Section Part No.	Size
1487B12	1487B24	1487B36	1487B48	1487B60	1487B120	2.5 x 2.5
1487C12	1487C24	1487C36	1487C48	1487C60	1487C120	4 x 4
1487D12	1487D24	1487D36	1487D48	1487D60	1487D120	6 x 6
1487E12	1487E24	1487E36	1487E48	1487E60	1487E120	8 x 8

One flat sealing plate included

Wireway & Trough

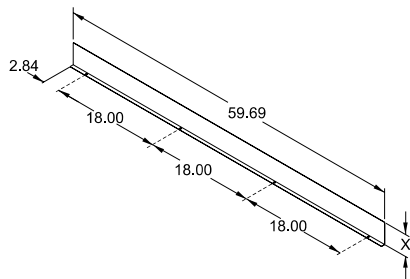

Partition (Barrier) Kit

- Divides wireway into two or more compartments. Barriers are fastened to wireway sections with screws.

Part No.	Size	X
1487CB60	4 x 4	3.72
1487DB60	6 x 6	5.72
1487EB60	8 x 8	7.72

Does not meet CSA or UL requirements

Pull Through Wireway

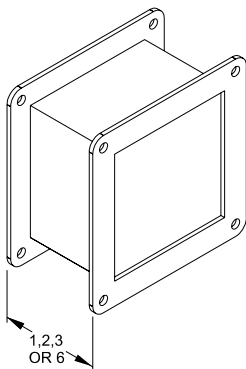

Typical Nipple

1" Nipple Part No.	2" Nipple Part No.	3" Nipple Part No.	6" Nipple Part No.	Size
1487BM1	1487BM2	1487BM3	1487BM6	2.5 x 2.5
1487CM1	1487CM2	1487CM3	1487CM6	4 x 4
1487DM1	1487DM2	1487DM3	1487DM6	6 x 6
1487EM1	1487EM2	1487EM3	1487EM6	8 x 8

One flat sealing plate included

Box Entry or Standard Swivel Nipple

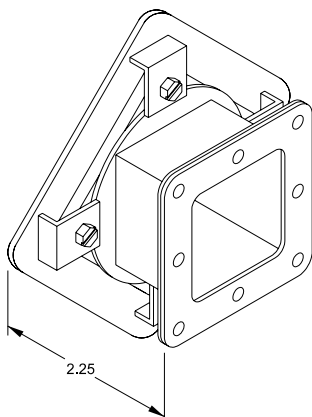

Box Entry Swivel Nipple Part No.	Standard Swivel Nipple Part No.	Size
1487BV1 ¹	1487BV2 ²	2.5 x 2.5
1487CV1 ¹	1487CV2 ²	4 x 4
1487DV1 ¹	1487DV2 ²	6 x 6
1487EV1 ¹	1487EV2 ²	8 x 8

Technical references and DXF downloads available at www.hammsg.com

All dimensions in inches unless specified otherwise

1487 Series Pull Through Wireway - NEMA 12

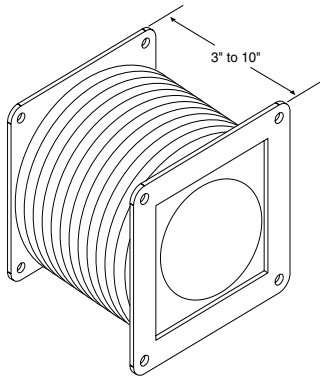

Flexible Fitting

- Allows for easy alignment of sections or fittings
- Metal flanges
- Flexible synthetic "bellows" middle section

Part No.	A	B
1485BFF	2.5	2.5
1485CFF	4	4
1485DFF	6	6
1485EFF	8	8

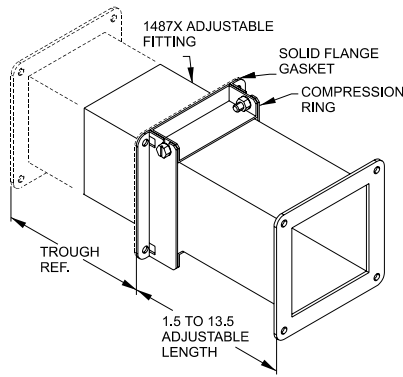

Adjustable Fitting

- Allows on site length adjustment of 1.5" to 13.5"

Part No.	Size
1487BX	2.5 x 2.5
1487CX	4 x 4
1487DX	6 x 6
1487EX	8 x 8

Does not meet CSA or UL requirements

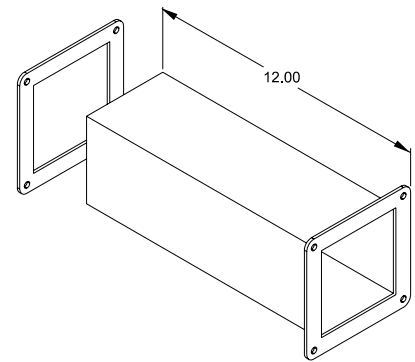

Cut-Off Fitting (Lay-In)

- Body comes in two pieces. Cut-off one piece, shorten cover, and weld together.
- Includes angle sealing plate.

Part No.	Size
1487BW	2.5 x 2.5
1487CW	4 x 4
1487DW	6 x 6
1487EW	8 x 8

Does not meet CSA or UL requirements

Wireway & Trough

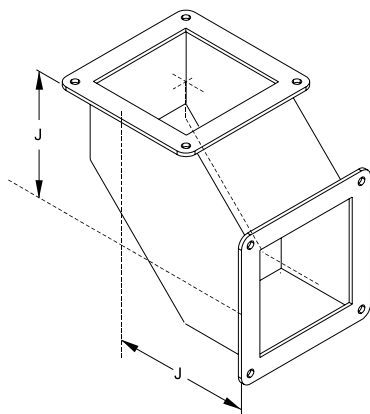

90° Elbow

Part No.	Size	J
1487B9P	2.5 x 2.5	4.25
1487C9P	4 x 4	5.00
1487D9P	6 x 6	6.00
1487E9P	8 x 8	7.00

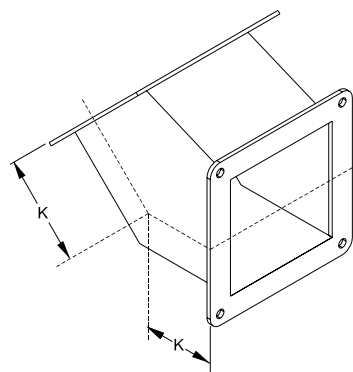

45° Elbow

Part No.	Size	K
1487B4P	2.5 x 2.5	1.98
1487C4P	4 x 4	2.42
1487D4P	6 x 6	3.00
1487E4P	8 x 8	3.62

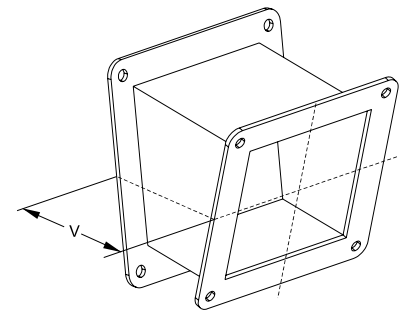

22.5° Elbow

Part No.	Size	V
1487B2P	2.5 x 2.5	3.18
1487C2P	4 x 4	3.75
1487D2P	6 x 6	4.43
1487E2P	8 x 8	5.12

Pull Through Wireway

1487 Series Pull Through Wireway - NEMA 12

Wireway & Trough

Pull Through Wireway

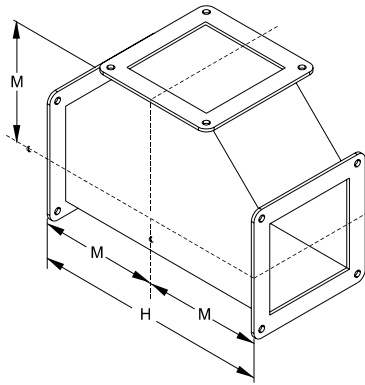

Tee Fitting

Part No.	Size	H	M
1487BT	2.5 x 2.5	8.50	4.25
1487CT	4 x 4	10.00	5.00
1487DT	6 x 6	12.00	6.00
1487ET	8 x 8	14.00	7.00

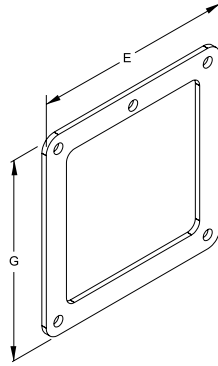

Box Connector

Part No.	Size	E	G
1487BK	2.5 x 2.5	3.87	3.87
1487CK	4 x 4	5.37	5.37
1487DK	6 x 6	7.62	7.62
1487EK	8 x 8	9.62	9.62

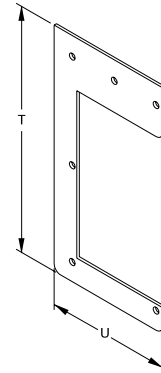

Drop Hanger

Part No.	Size	T	U
1485BL1	2.5 x 2.5	9.25	4.50
1485CL1	4 x 4	11.75	6.00
1485DL1	6 x 6	15.25	8.12
1485EL1	8 x 8	20.56	12.12

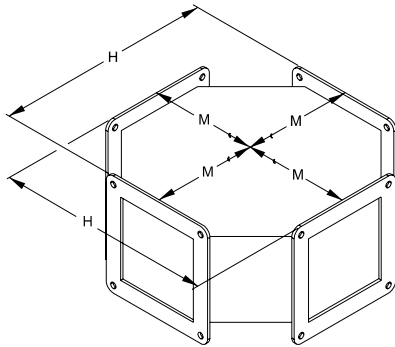

Cross Fitting

Part No.	Size	H	M
1487BY	2.5 x 2.5	8.50	4.25
1487CY	4 x 4	10.00	5.00
1487DY	6 x 6	12.00	6.00
1487EY	8 x 8	14.00	7.00

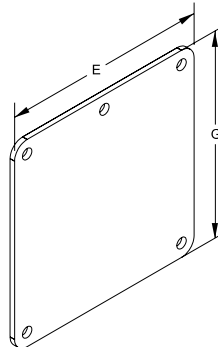

Cover Plate

Part No.	Size	E	G
1487BH	2.5 x 2.5	3.87	3.87
1487CH	4 x 4	5.37	5.37
1487DH	6 x 6	7.62	7.62
1487EH	8 x 8	9.62	9.62

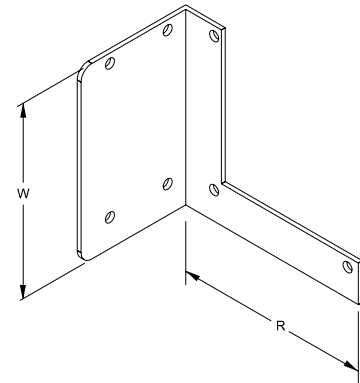

Bracket Hanger

Part No.	Size	R	W
1485BL2	2.5 x 2.5	4.62	4.37
1485CL2	4 x 4	6.12	5.87
1485DL2	6 x 6	8.25	7.87
1485EL2	8 x 8	10.25	9.87

1487 Series Pull Through Wireway - NEMA 12

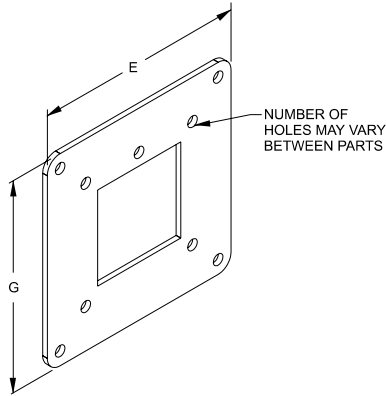

Reducers (Center Hole)

Part No.	Reduces from	to	E	G
1487CRC	4 x 4	2.5 x 2.5	5.37	5.37
1487DRC	6 x 6	4 x 4	7.62	7.62
1487ERCC	8 x 8	4 x 4	9.62	9.62
1487ERCD	8 x 8	6 x 6	9.62	9.62

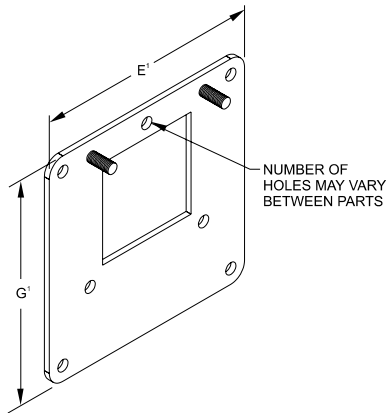

Reducers (Edge Hole)

Part No.	Reduces from	to	E	G
1487CRE	4 x 4	2.5 x 2.5	5.37	5.37
1487DRE	6 x 6	4 x 4	7.62	7.62
1487EREC	8 x 8	4 x 4	9.62	9.62
1487ERED	8 x 8	6 x 6	9.62	9.62

Wireway & Trough

Pull Through Wireway