

Customer Information Sheet

DRAWING No.: M80-858XX22 SHEET 2 OF 2 IF IN DOUBT - ASK © NOT TO SCALE THIRD ANGLE PROJECTION ALL DIMENSIONS IN mm

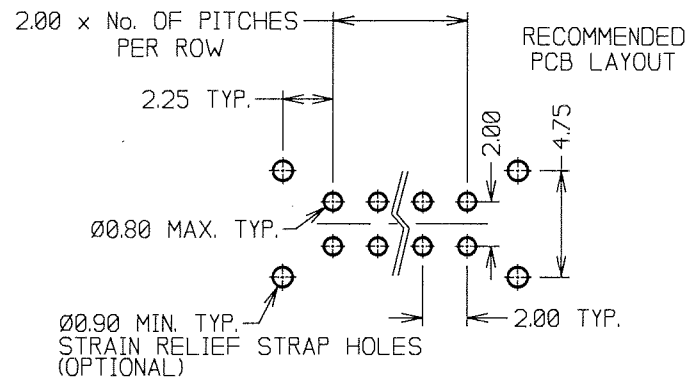
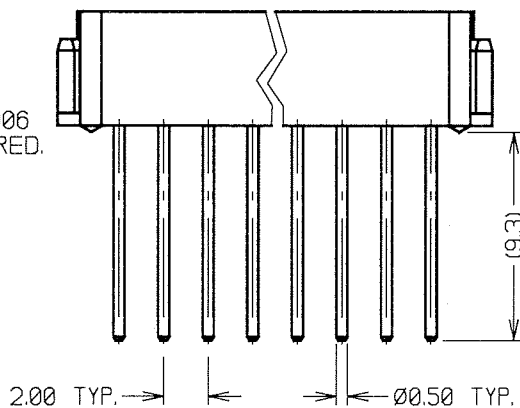
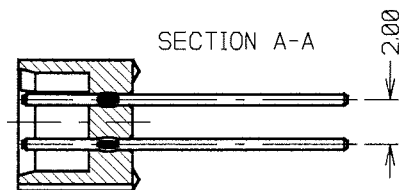
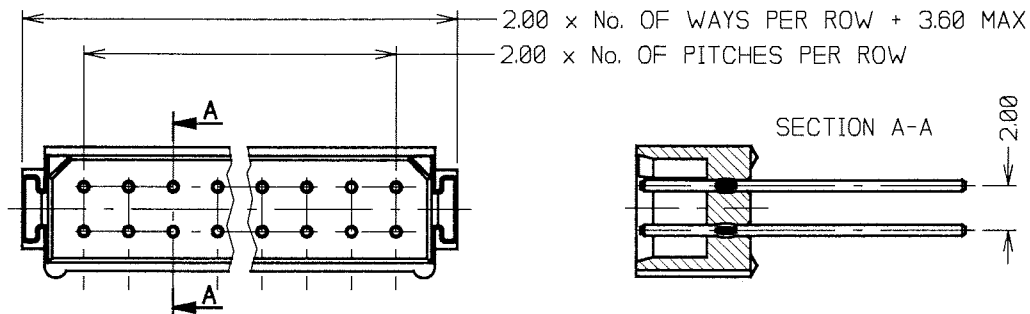
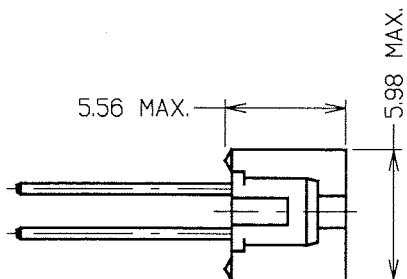

NOTES:

1. 2-OFF STRAIN RELIEF STRAP M80-0030006 CAN BE ORDERED SEPERATELY IF REQUIRED.

SPECIFICATIONS:

MATERIAL:

MOULDING - GLASS-FILLED
POLYESTER UL94V-0

CONTACT - PHOSPHOR BRONZE

FINISH:

CONTACTS - 0.75µ GOLD ON CONTACT AREA,
3.0µ 90/10 TIN/LEAD ON TAILS

ELECTRICAL:

CURRENT RATING AT 25°C - 3.0A MAX

CURRENT RATING AT 85°C - 2.2A MAX

WORKING VOLTAGE - 120V AC/DC

VOLTAGE PROOF - 360V AC/DC

CONTACT RESISTANCE (INITIAL) -

20 MILLIOHMS MAX

CONTACT RESISTANCE (AFTER

CONDITIONING) - 25 MILLIOHMS MAX

INSULATION RESISTANCE (INITIAL) -

1000 MEGOHMS MIN

INSULATION RESISTANCE (AFTER

CONDITIONING) - 100 MEGOHMS MIN

MECHANICAL:

DURABILITY = 500 OPERATIONS

ENVIRONMENTAL:

TEMPERATURE RANGE - -55°C TO +125°C

PACKING:

TUBE

FOR COMPLETE SPECIFICATION, SEE COMPONENT SPECIFICATION C005XX (LATEST ISSUE)

BRITISH STANDARD
ORDER CODE:

B5743-2XX-M-T-V

TOTAL No. OF WAYS
10, 12, 14, 20, 26 & 34

FINISH: _____
Ø - SELECTIVE GOLD

COMMERCIAL
ORDER CODE:

M80-858XX22

TOTAL No. OF WAYS
10, 12, 14, 20, 26 & 34

FINISH: _____
SELECTIVE GOLD

MGP	5	09.08.07	9839
NAME	ISS.	DATE	C/NOTE
APPROVED: <i>[Signature]</i>			
CHECKED: <i>[Signature]</i>			
DRAWN:		M.A. TODD	
CUSTOMER REF.:			
ASSEMBLY DRG.:			

HARWIN

HARWIN USA TEL: 603 893 5376 FAX: 603 893 5396 mls@harwin.com
HARWIN Europe (UK) TEL: 023 9231 4545 FAX: 023 9231 4590 mls@harwin.co.uk
HARWIN Asia TEL: +65 6 779 4909 FAX: +65 6 779 3868 mls@harwin.com.sg

THIS DRAWING AND ANY INFORMATION OR DESCRIPTIVE MATTER SET OUT HEREON ARE CONFIDENTIAL AND COPYRIGHT PROPERTY OF THE HARWIN GROUP AND MUST NOT BE DISCLOSED, LOANED, COPIED OR USED FOR MANUFACTURING, TENDERING OR FOR ANY OTHER PURPOSE WITHOUT THEIR WRITTEN PERMISSION.

TOLERANCES
X. = ±1mm
X.X = ±0.25mm
X.XX = ±0.10mm
X.XXX = ±0.01mm
ANGLES = ±5°
UNLESS STATED

MATERIAL: SEE ABOVE
FINISH: SEE ABOVE
S/AREA: mm²

TITLE: DATAMATE 2mm PITCH
VERTICAL PC TAIL DIL PLUG
ASSEMBLY - UNLATCHED
DRAWING NUMBER:
M80-858XX22

SHT
2
OF
2