

# Customer Information Sheet

DRAWING No.: M20-973XXXX

SHEET 2 OF 2

IF IN DOUBT - ASK

(C)

NOT TO SCALE

THIRD ANGLE PROJECTION

ALL DIMENSIONS IN mm

**NOTES:**

1. RECOMMENDED PCB MOUNTING HOLE SIZE =  $\varnothing 1.00\text{mm}$ .
2. ALL TOLERANCES ARE  $\pm 0.25\text{mm}$  UNLESS OTHERWISE STATED.
3. FOR COMPLETE SPECIFICATION, SEE COMPONENT SPECIFICATION C001XX (LATEST ISSUE).

**SPECIFICATION:**

**MATERIAL:**  
 MOULDING = HIGH TEMP NYLON 6T UL94V-0, BLACK  
 PINS = BRASS  
**FINISH:**  
 PINS:  
 45 = GOLD  
 46 = 100% TIN OVER NICKEL  
**ELECTRICAL:**  
 CURRENT RATING = 3A MAX  
 CONTACT RESISTANCE = 25 m $\Omega$  MAX (GOLD), 30 m $\Omega$  MAX (TIN)  
 INSULATION RESISTANCE = 1,000 M $\Omega$  MIN  
 DIELECTRIC STRENGTH = 750V AC/DC  
**MECHANICAL:**  
 DURABILITY = 300 OPERATIONS (GOLD), 50 OPERATIONS (TIN)  
**ENVIRONMENTAL:**  
 TEMPERATURE RANGE = -40°C TO +105°C  
**PACKING:**  
 BAG

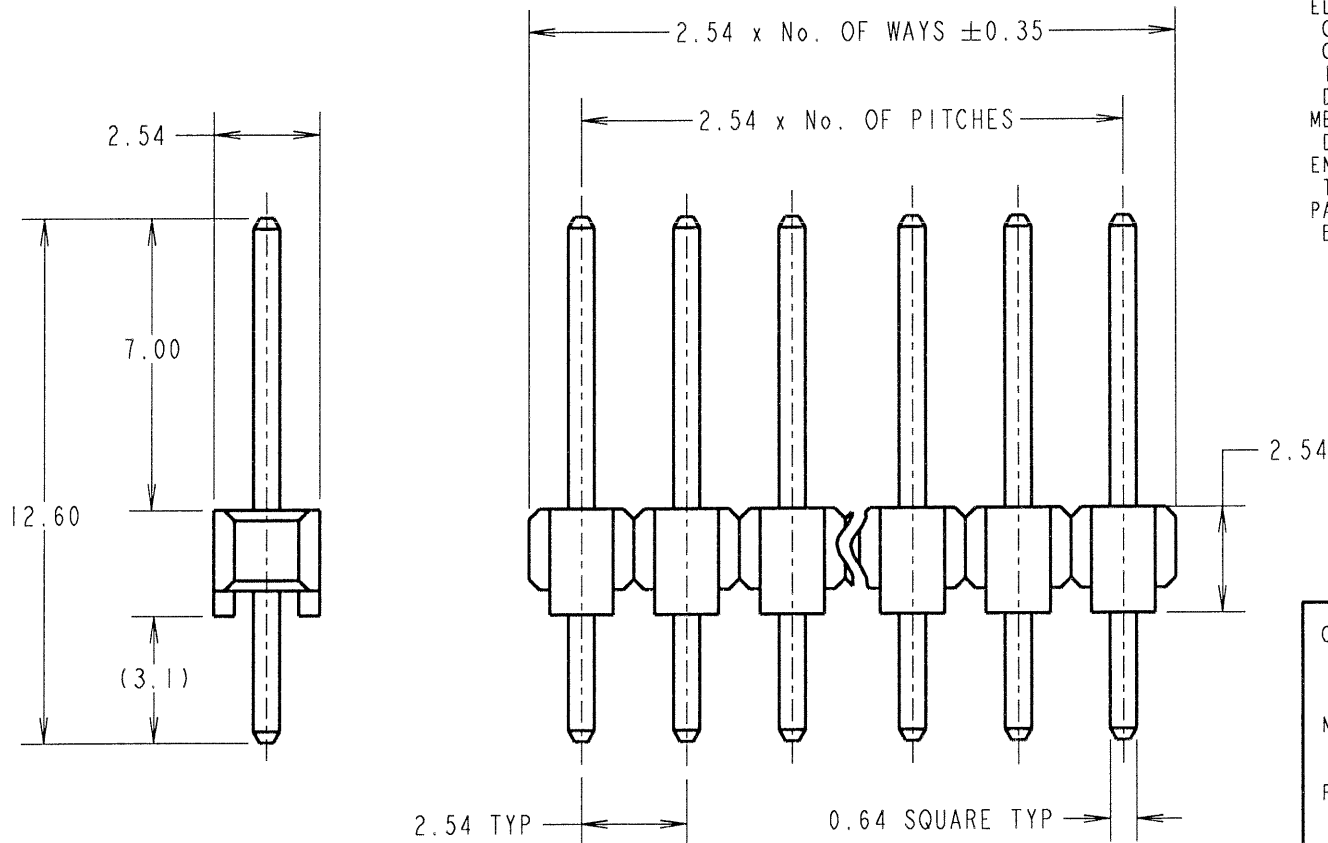

ORDER CODE:  
**M20-973XXXX**

No. OF WAYS: \_\_\_\_\_  
 02 TO 40

FINISH: \_\_\_\_\_  
 45 = GOLD  
 46 = 100% TIN

JMB	11	05.12.06	9602
NAME	ISS.	DATE	C/NOTE
APPROVED: <i>JMB</i>			
CHECKED: <i>[Signature]</i>			
DRAWN: J. CLAY			
CUSTOMER REF.:			
ASSEMBLY DRG:			

**HARWIN**

HARWIN INC U.S.A. TEL: (812) 542 2540 FAX: (812) 542 2541	HARWIN PLC U.K. TEL: 023 9231 4545 FAX: 023 9231 4590	HARWIN PTE SINGAPORE TEL: 65 6779 4909 FAX: 65 6779 3868
--	--	---

THIS DRAWING AND ANY INFORMATION OR DESCRIPTIVE MATTER SET OUT HEREON ARE CONFIDENTIAL AND COPYRIGHT PROPERTY OF THE HARWIN GROUP AND MUST NOT BE DISCLOSED, LOANED, COPIED OR USED FOR MANUFACTURING, TENDERING OR FOR ANY OTHER PURPOSE WITHOUT THEIR WRITTEN PERMISSION.

**TOLERANCES**  
 ~~$\forall$  =  $\pm 1\text{mm}$~~   
~~X.X =  $\pm 0.25\text{mm}$~~   
~~X.XX =  $\pm 0.10\text{mm}$~~   
~~X.XXX =  $\pm 0.01\text{mm}$~~   
 ANGLES =  $\pm 5^\circ$   
 UNLESS STATED

**MATERIAL:**  
 SEE ABOVE

**FINISH:**  
 SEE ABOVE

**S/AREA:** \_\_\_\_\_ mm<sup>2</sup>

**TITLE:** 2.54mm PITCH SIL VERTICAL PC TAIL PIN HEADER ASSEMBLY

**DRAWING NUMBER:** M20-973XXXX

SHT 2 OF 2