

Customer Information Sheet

DRAWING No.: M90-3106F10SL-3P

SHEET 2 OF 2

IF IN DOUBT - ASK

©

THIRD ANGLE PROJECTION

NOT TO SCALE

ALL DIMENSIONS IN mm

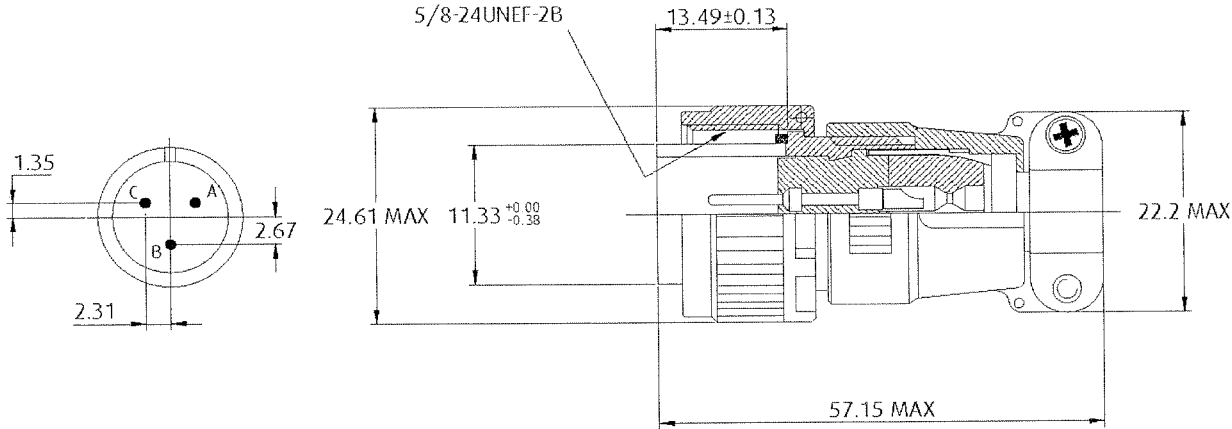

SPECIFICATIONS:

MATERIAL:

- SHELL = ALUMINIUM ALLOY
- INSULATOR = POLYCHLOROPRENE
- GROMMET = POLYCHLOROPRENE
- CONTACT = COPPER ALLOY

FINISH:

- SHELL = ZINC WITH BLACK CHROMATE COATING
- CONTACT = SILVER

ELECTRICAL:

- CURRENT RATING = 13 AMPS
- VOLTAGE RATING = 500V AC, 700V DC
- INSULATION RESISTANCE = 5,000 MΩ MIN

ENVIRONMENTAL:

- TEMPERATURE RANGE = -55°C TO +125°C
- VIBRATION = 10 - 500Hz (10G) PER MIL-STD-1344, Method 2005
- SALT SPRAY = 48 HRS, 5% SALT SOLUTION, PER MIL-STD-1344 Method 1001
- HUMIDITY = 95±3%, 71±2°C, 14 DAYS

MECHANICAL:

- COUPLING : THREADED
- POLARISATION : SINGLE KEY/ KEYWAY
- CONTACT TYPE : SOLDER
- CONTACT ARRANGEMENT : 3 CONTACTS
- DURABILITY : 500 OPERATIONS

RA	2	28.09.07	9869
NAME	ISS.	DATE	C/NOTE
APPROVED			
CHECKED:			
DRAWN:		M.G.PLESTED	
CUSTOMER REF:			
ASSEMBLY DRG:			

HARWIN

THIS INFORMATION AND ANY INFORMATION OR DESCRIPTIVE MATTER SET OUT HEREON ARE CONFIDENTIAL AND COPYRIGHT PROPERTY OF THE HARWIN GROUP AND MUST NOT BE DISCLOSED, LOANED, COPIED OR USED FOR MANUFACTURING, TENDERING OR FOR ANY OTHER PURPOSE WITHOUT THEIR WRITTEN PERMISSION.

TOLERANCES

- X. = ±1mm
- X.X = ±0.25mm
- X.XX = ±0.10mm
- X.XXX = ±0.01mm
- ANGLES = ±5°
- UNLESS STATED

MATERIAL:

SEE ABOVE

FINISH:

SEE ABOVE

S/AREA:

TITLE:

FREE PLUG -
3 PIN CONTACTS

DRAWING NUMBER:

M90-3106F10SL-3P

SHT

2

OF

2

HARWIN USA

TEL: 603 893 5376

FAX: 603 893 5396

mis@harwin.com

HARWIN Europe (UK)

TEL: 023 9231 4545

FAX: 023 9231 4590

mis@harwin.co.uk

HARWIN Asia

TEL: +65 6 779 4909

FAX: +65 6 779 3868

mis@harwin.com.sg

Customer Information Sheet

DRAWING No.: M90-3106F10SL-4P

SHEET 2 OF 2

IF IN DOUBT - ASK

©

THIRD ANGLE PROJECTION

NOT TO SCALE

ALL DIMENSIONS IN mm

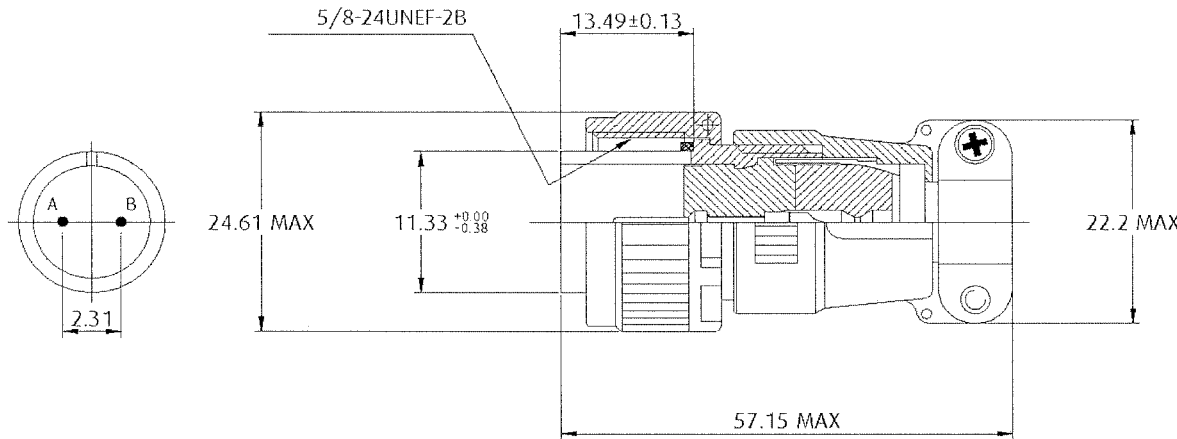

SPECIFICATIONS:

MATERIAL:

SHELL = ALUMINIUM ALLOY
 INSULATOR = POLYCHLOROPRENE
 GROMMET = POLYCHLOROPRENE
 CONTACT = COPPER ALLOY

FINISH:

SHELL = ZINC WITH BLACK CHROMATE COATING
 CONTACT = SILVER

ELECTRICAL:

CURRENT RATING = 13 AMPS
 VOLTAGE RATING = 500V AC, 700V DC
 INSULATION RESISTANCE = 5,000 MΩ MIN

ENVIRONMENTAL:

TEMPERATURE RANGE = -55°C TO +125°C
 VIBRATION = 10 - 500Hz (10G) PER MIL-STD-1344, Method 2005
 SALT SPRAY = 48 HRS, 5% SALT SOLUTION, PER MIL-STD-1344 Method 1001

HUMIDITY = 95±3%, 71±2°C, 14 DAYS

MECHANICAL:

COUPLING : THREADED
 POLARISATION : SINGLE KEY/ KEYWAY
 CONTACT TYPE : SOLDER
 CONTACT ARRANGEMENT : 2 CONTACTS
 DURABILITY : 500 OPERATIONS

RA	2	28.09.07	9869
NAME	ISS.	DATE	C/NOTE
APPROVED <i>[Signature]</i>			
CHECKED: <i>[Signature]</i>			
DRAWN: M.G.PLESTED			
CUSTOMER REF:			
ASSEMBLY DRG:			

HARWIN

THIS INFORMATION AND ANY INFORMATION OR DESCRIPTIVE MATTER SET OUT HEREON ARE CONFIDENTIAL AND COPYRIGHT PROPERTY OF THE HARWIN GROUP AND MUST NOT BE DISCLOSED, LOANED, COPIED OR USED FOR MANUFACTURING, TENDERING OR FOR ANY OTHER PURPOSE WITHOUT THEIR WRITTEN PERMISSION.

TOLERANCES

X. = ±1mm
 X.X = ±0.25mm
 X.XX = ±0.10mm
 X.XXX = ±0.01mm
 ANGLES = ±5°
 UNLESS STATED

MATERIAL:

SEE ABOVE

FINISH:

SEE ABOVE

S/AREA:

TITLE:

FREE PLUG -
 2 PIN CONTACTS

DRAWING NUMBER:

M90-3106F10SL-4P

SHT
 2
 OF
 2

HARWIN USA
 TEL: 603 893 5376
 FAX: 603 893 5396
 mis@harwin.com

HARWIN Europe (UK)
 TEL: 023 9231 4545
 FAX: 023 9231 4590
 mis@harwin.co.uk

HARWIN Asia
 TEL: +65 6 779 4909
 FAX: +65 6 779 3868
 mis@harwin.com.sg

Customer Information Sheet

DRAWING No.: M90-3106F12S-3P

SHEET 2 OF 2

IF IN DOUBT - ASK

(C)

NOT TO SCALE

THIRD ANGLE PROJECTION

ALL DIMENSIONS IN mm

SPECIFICATIONS:

MATERIAL:

SHELL: ALUMINIUM ALLOY
 INSULATOR: NITRILE BUTADIENE RUBBER
 GROMMET: NITRILE BUTADIENE RUBBER
 CONTACT COPPER ALLOY

FINISH:

SHELL: ZINC PLATED WITH BLACK CHROMATE COATING
 CONTACT: SILVER

ELECTRICAL:

CURRENT RATING: 13 AMPS
 VOLTAGE RATING: 500V AC, 700V DC
 INSULATION RESISTANCE: 5,000 MΩ MIN

MECHANICAL:

COUPLING: THREADED
 POLARISATION: SINGLE KEY/KEYWAY
 CONTACT TYPE: SOLDER
 CONTACT ARRANGEMENT: 2 CONTACTS
 DURABILITY: 500 CYCLES

ENVIRONMENTAL:

TEMPERATURE RANGE: -55°C TO -125°C
 VIBRATION: 10-500Hz (10G), PER MIL-STD-1344, METHOD 2005
 SALT SPRAY: 48HRS. SALT SOLUTION 5%, PER MIL-1344, METHOD 1001
 HUMIDITY: RELATIVE HUMIDITY 95±3%, 71°C±2°C, 14 DAYS

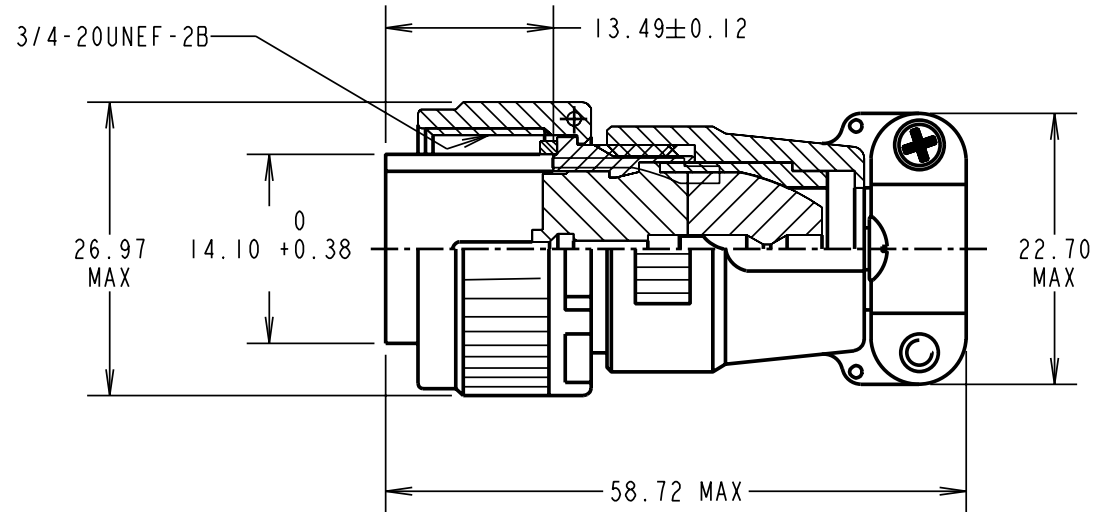
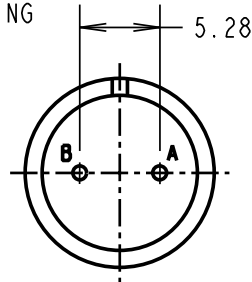

NOTES:

1. PRODUCT IS RoHS COMPLIANT
2. PRODUCT IS PACKED IN BAGS.

RA	1	17.07.08	----
NAME	ISS.	DATE	C/NOTE
APPROVED: R.ADDE			
CHECKED: MARK PLESTED			
DRAWN: R.ADDE			
CUSTOMER REF.:			
ASSEMBLY DRG:			

HARWIN

HARWIN USA TEL: 603 893 5376 FAX: 603 893 5396 mis@harwin.com	HARWIN Europe (UK) TEL: 023 9231 4545 FAX: 023 9231 4590 mis@harwin.co.uk	HARWIN Asia TEL: +65 6 779 4909 FAX: +65 6 779 3868 mis@harwin.com.sg
--	--	--

THIS DRAWING AND ANY INFORMATION OR DESCRIPTIVE MATTER SET OUT HEREON ARE CONFIDENTIAL AND COPYRIGHT PROPERTY OF THE HARWIN GROUP AND MUST NOT BE DISCLOSED, LOANED, COPIED OR USED FOR MANUFACTURING, TENDERING OR FOR ANY OTHER PURPOSE WITHOUT THEIR WRITTEN PERMISSION.

TOLERANCES
 X. = ±1mm
 X.X = ±0.25mm
 X.XX = ±0.10mm
 X.XXX = ±0.01mm
 ANGLES = ±5°
 UNLESS STATED

MATERIAL:
 SEE ABOVE
FINISH:
S/AREA: mm²

TITLE:
 CABLE CONNECTOR-
 2 PIN CONTACTS
DRAWING NUMBER:
 M90-3106F12S-3P

SHT
 2 OF 2

Customer Information Sheet

DRAWING No.: M90-3106F14S-2P

SHEET 2 OF 2

IF IN DOUBT - ASK

©

THIRD ANGLE PROJECTION

NOT TO SCALE

ALL DIMENSIONS IN mm

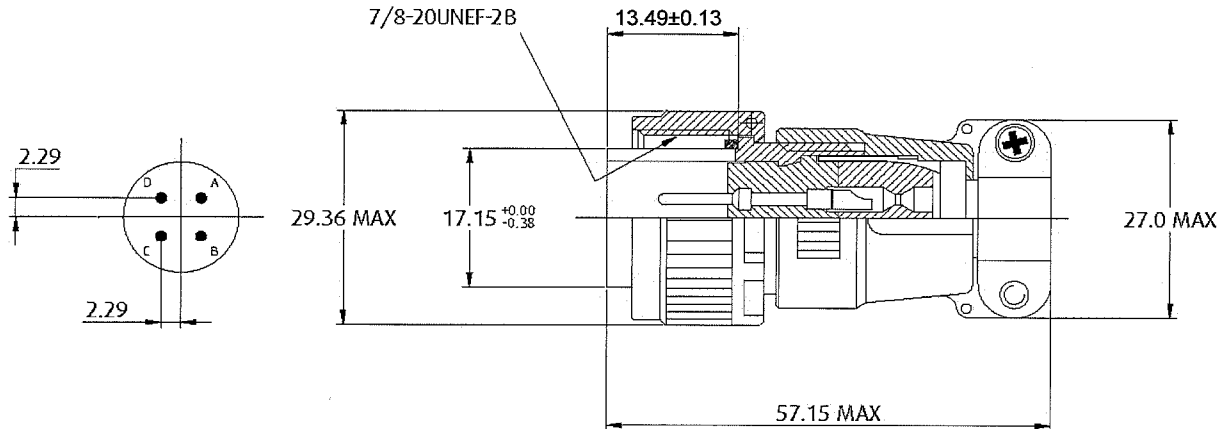

SPECIFICATIONS:

MATERIAL:

SHELL = ALUMINIUM ALLOY

INSULATOR = POLYCHLOROPRENE

GROMMET = POLYCHLOROPRENE

CONTACT = COPPER ALLOY

FINISH:

SHELL = ZINC WITH BLACK CHROMATE COATING

CONTACT = SILVER

ELECTRICAL:

CURRENT RATING = 13 AMPS

VOLTAGE RATING = 200V AC, 250V DC

INSULATION RESISTANCE = 5,000 MΩ MIN

ENVIRONMENTAL:

TEMPERATURE RANGE = -55°C TO +125°C

VIBRATION = 10 - 500Hz (10G) PER MIL-STD-1344, Method 2005

SALT SPRAY = 48 HRS, 5% SALT SOLUTION, PER MIL-STD-1344

Method 1001

HUMIDITY = 95±3%, 71±2°C, 14 DAYS

MECHANICAL:

COUPLING : THREADED

POLARISATION : SINGLE KEY/ KEYWAY

CONTACT TYPE : SOLDER

CONTACT ARRANGEMENT : 4 CONTACTS

DURABILITY : 500 OPERATIONS

RA	3	03.11.08	10198
NAME	ISS.	DATE	C/NOTE
APPROVED <i>[Signature]</i>			
CHECKED: <i>[Signature]</i>			
DRAWN:		M.G.PLESTED	
CUSTOMER REF:			
ASSEMBLY DRG:			

HARWIN

THIS INFORMATION AND ANY INFORMATION OR DESCRIPTIVE MATTER SET OUT HEREON ARE CONFIDENTIAL AND COPYRIGHT PROPERTY OF THE HARWIN GROUP AND MUST NOT BE DISCLOSED, LOANED, COPIED OR USED FOR MANUFACTURING, TENDERING OR FOR ANY OTHER PURPOSE WITHOUT THEIR WRITTEN PERMISSION.

TOLERANCES

X. = ±1mm

X.X = ±0.25mm

X.XX = ±0.10mm

X.XXX = ±0.01mm

ANGLES = ±5°

UNLESS STATED

MATERIAL:

SEE ABOVE

FINISH:

SEE ABOVE

S/AREA:

TITLE:

FREE PLUG -
4 PIN CONTACTS

DRAWING NUMBER:

M90-3106F14S-2P

SHT

2

OF

2

HARWIN USA

TEL: 603 893 5376

FAX: 603 893 5396

mis@harwin.com

HARWIN Europe (UK)

TEL: 023 9231 4545

FAX: 023 9231 4590

mis@harwin.co.uk

HARWIN Asia

TEL: +65 6 779 4909

FAX: +65 6 779 3868

mis@harwin.com.sg

Customer Information Sheet

DRAWING No.: M90-3106F14S-6P

SHEET 2 OF 2

IF IN DOUBT - ASK

©

THIRD ANGLE PROJECTION

NOT TO SCALE

ALL DIMENSIONS IN mm

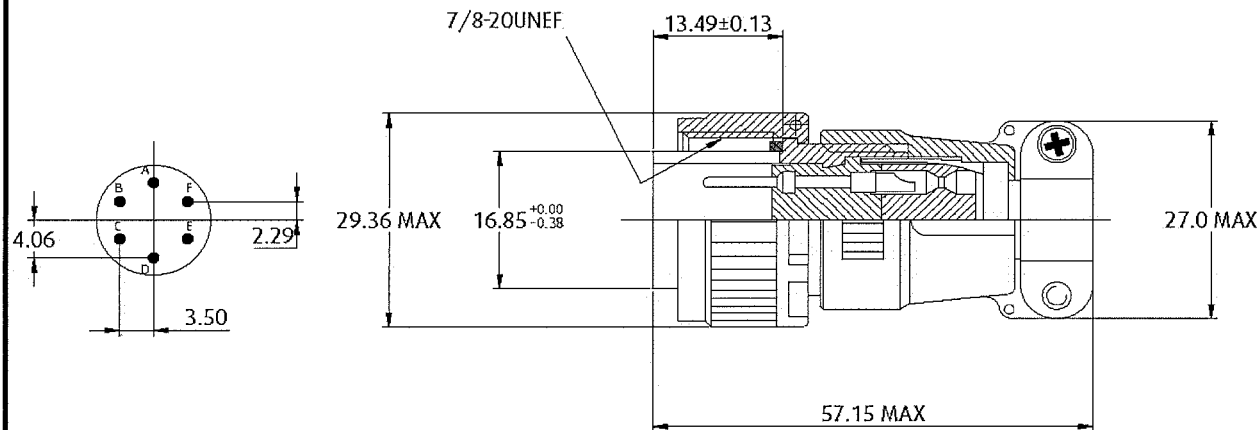

SPECIFICATIONS:

MATERIAL:

SHELL = ALUMINIUM ALLOY

INSULATOR = POLYCHLOROPRENE

GROMMET = POLYCHLOROPRENE

CONTACT = COPPER ALLOY

FINISH:

SHELL = ZINC WITH BLACK CHROMATE COATING

CONTACT = SILVER

ELECTRICAL:

CURRENT RATING = 13 AMPS

VOLTAGE RATING = 200V AC, 250V DC

INSULATION RESISTANCE = 5,000 MΩ MIN

ENVIRONMENTAL:

TEMPERATURE RANGE = -55°C TO +125°C

VIBRATION = 10 - 500Hz (10G) PER MIL-STD-1344, Method 2005

SALT SPRAY = 48 HRS, 5% SALT SOLUTION, PER MIL-STD-1344
Method 1001

HUMIDITY = 95±3%, 71±2°C, 14 DAYS

MECHANICAL:

COUPLING : THREADED

POLARISATION : SINGLE KEY/ KEYWAY

CONTACT TYPE : SOLDER

CONTACT ARRANGEMENT : 6 CONTACTS

DURABILITY : 500 OPERATIONS

RA	3	03.11.08	10198
NAME	ISS.	DATE	C/NOTE
APPROVED	<i>[Signature]</i>		
CHECKED:	<i>[Signature]</i>		
DRAWN:	M.G.PLESTED		
CUSTOMER REF:			
ASSEMBLY DRG:			

HARWIN

THIS INFORMATION AND ANY INFORMATION OR DESCRIPTIVE MATTER SET OUT HEREON ARE CONFIDENTIAL AND COPYRIGHT PROPERTY OF THE HARWIN GROUP AND MUST NOT BE DISCLOSED, LOANED, COPIED OR USED FOR MANUFACTURING, TENDERING OR FOR ANY OTHER PURPOSE WITHOUT THEIR WRITTEN PERMISSION.

TOLERANCES

X. = ±1mm

X.X = ±0.25mm

X.XX = ±0.10mm

X.XXX = ±0.01mm

ANGLES = ±5°

UNLESS STATED

MATERIAL:

SEE ABOVE

FINISH:

SEE ABOVE

S/AREA:

TITLE:

FREE PLUG -
6 PIN CONTACTS

DRAWING NUMBER:

M90-3106F14S-6P

SHT

2

OF

2

HARWIN USA

TEL: 603 893 5376

FAX: 603 893 5396

mis@harwin.com

HARWIN Europe (UK)

TEL: 023 9231 4545

FAX: 023 9231 4590

mis@harwin.co.uk

HARWIN Asia

TEL: +65 6 779 4909

FAX: +65 6 779 3868

mis@harwin.com.sg