

Customer Information Sheet

DRAWING No.: R6490-00 - R6493-00 SHEET 2 OF 2 IF IN DOUBT - ASK (C) NOT TO SCALE THIRD ANGLE PROJECTION ALL DIMENSIONS IN mm

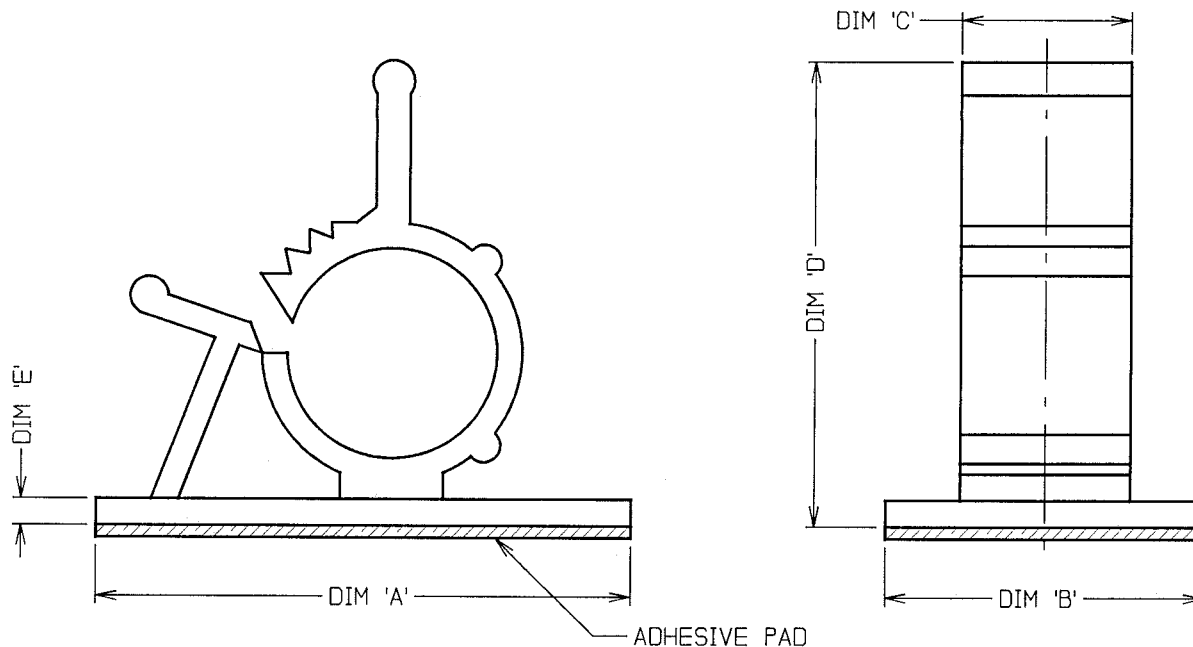

ORDER CODE:
R649X-00
SIZE CODE _____
(SEE TABLE)

- NOTES:
1. ALL DIMENSIONS ARE ± 0.50 UNLESS OTHERWISE STATED.
2. TEMPERATURE RANGE = -40°C TO $+85^{\circ}\text{C}$.

2	01.02.99	4714
1	07.07.92	----
ISS.	DATE	C/NOTE
APPROVED:		
CHECKED: <i>DJB</i>		
DRAWN: D. BECK		
CUSTOMER REF.:		
ASSEMBLY DRG.:		

PART No.	CABLE BUNDLE DIAMETER	DIM 'A'	DIM 'B'	DIM 'C'	DIM 'D'	DIM 'E'
R6490-00	$\varnothing 7.9 - 10.3\text{mm}$	25.40	19.10	10.20	22.20	1.60
R6491-00	$\varnothing 10.0 - 12.5\text{mm}$	31.80	19.10	10.20	27.80	1.60
R6492-00	$\varnothing 12.6 - 15.4\text{mm}$	36.70	18.40	12.10	31.80	3.02
R6493-00	$\varnothing 16.5\text{mm} - 20.1\text{mm}$	42.19	25.40	12.70	39.66	3.13

HARWIN

HARWIN INC U.S.A. TEL: (812) 285 0055 FAX: (812) 285 0056	HARWIN PLC U.K. TEL: 01705 370451 FAX: 01705 314590	HARWIN PTE SINGAPORE TEL: 65 7794909 FAX: 65 7793868
--	--	---

THIS DRAWING AND ANY INFORMATION OR DESCRIPTIVE MATTER SET OUT HEREON ARE CONFIDENTIAL AND COPYRIGHT PROPERTY OF THE HARWIN GROUP AND MUST NOT BE DISCLOSED, LOANED, COPIED OR USED FOR MANUFACTURING, TENDERING OR FOR ANY OTHER PURPOSE WITHOUT THEIR WRITTEN PERMISSION.

TOLERANCES
X. - $\pm 1\text{mm}$
X.X - $\pm 0.25\text{mm}$
X.XX - $\pm 0.10\text{mm}$
X.XXX - $\pm 0.01\text{mm}$
ANGLES - $\pm 1^{\circ}$
UNLESS STATED

MATERIAL: NYLON 66 BLACK UL94V-2
FINISH: CLEAN
S/AREA: mm²

TITLE: ADJUSTABLE CABLE CLAMP
DRAWING NUMBER: R6490-00 - R6493-00

SHT 2 OF 2