

8K-BIT/16K-BIT SPI SERIAL ELECTRICALLY ERASABLE PROM

Preliminary Information
July 2008

FEATURES

- Serial Peripheral Interface (SPI) Compatible
 - Supports SPI Modes 0 (0,0) and 3 (1,1)
- Wide-voltage Operation
 - $V_{cc} = 1.8V$ to $5.5V$
- Low power CMOS
 - Operating current less than 1 mA ($1.8V$)
 - Standby current less than $1\text{ }\mu A$ ($1.8V$)
- Block Write Protection
 - Protect 1/4, 1/2, or Entire Array
- 16 byte page write mode
 - Partial page writes allowed
- 10 MHz Clock Rate ($5V$)
- Self timed write cycles (5 ms Typical)
- High-reliability
 - Endurance: 1 million cycles per byte
 - Data retention: 100 years
- Industrial and Automotive temperature ranges
- 8-pin PDIP, 8-pin SOIC/SOP, 8-pad DFN, 8-pin TSSOP, and 8-ball chip scale packages are available
- Lead-free available

DESCRIPTION

The IS25C08 and IS25C16 are electrically erasable PROM devices that use the Serial Peripheral Interface (SPI) for communications. The IS25C08 is 8Kbit (1024×8) and the IS25C16 is 16Kbit (2048×8). The IS25C08/16 EEPROMs are offered in a wide operating voltage range of $1.8V$ to $5.5V$ compatible with most application voltages. ISSI designed the IS25C08/16 to be an efficient SPI EEPROM solution. The devices are packaged in 8-pin PDIP, 8-pin SOIC, 8-pad DFN, 8-pin TSSOP, and 8-ball CSP.

The functional features of the IS25C08/16 allow them to be among the most advanced serial non-volatile memories available. Each device has a Chip-Select (\overline{CS}) pin, and a 3-wire interface of Serial Data In (SI), Serial Data Out (SO), and Serial Clock (SCK). While the 3-wire interface of the IS25C08/16 provides for high-speed access, a \overline{HOLD} pin allows the memories to ignore the interface in a suspended state; later the \overline{HOLD} pin re-activates communication without re-initializing the serial sequence. A Status Register facilitates a flexible write protection mechanism, and a device-ready bit (\overline{RDY}).

PIN CONFIGURATION

8-Pin DIP, SOIC, and TSSOP

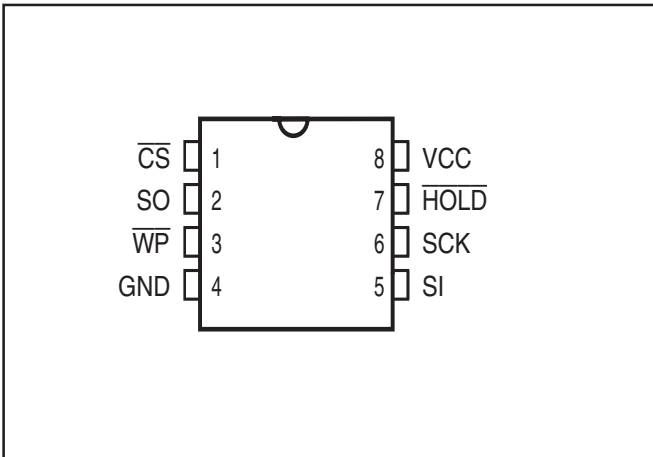

8-pad DFN

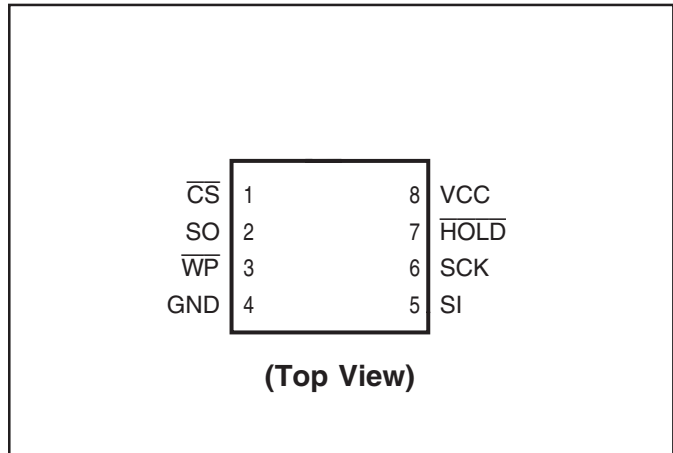

PIN DESCRIPTIONS

$\overline{\text{CS}}$	Chip Select
SCK	Serial Data Clock
SI	Serial Data Input
SO	Serial Data Output
GND	Ground
V _{CC}	Power
$\overline{\text{WP}}$	Write Protect
$\overline{\text{HOLD}}$	Suspends Serial Input

PIN DESCRIPTIONS

Serial Clock (SCK): This timing signal provides synchronization between the microcontroller and IS25C08/16. Op-Codes, byte addresses, and data are latched on SI with a rising edge of the SCK. Data on SO is refreshed on the falling edge of SCK for SPI modes (0,0) and (1,1).

Serial Data Input (SI): This is the input pin for all data that the IS25C08/16 is required to receive.

Serial Data Output (SO): This is the output pin for all data transmitted from the IS25C08/16.

Chip Select ($\overline{\text{CS}}$): The $\overline{\text{CS}}$ pin activates the device. Upon power-up, $\overline{\text{CS}}$ should follow V_{CC}. When the device is to be enabled for instruction input, the signal requires a High-to-Low transition. While $\overline{\text{CS}}$ is stable Low, the master and slave will communicate via SCK, SI, and SO signals. Upon completion of communication, $\overline{\text{CS}}$ must be driven High. At this moment, the slave device may start its internal write cycle. When $\overline{\text{CS}}$ is high, the device enters a power-saving standby mode, unless an internal write operation is underway. During this mode, the SO pin becomes high impedance.

Write Protect ($\overline{\text{WP}}$): The purpose of this input signal is to initiate Hardware Write Protection mode. This mode prevents the Block Protection bits and the WPEN bit in the Status Register from being altered. To cause Hardware Write Protection, $\overline{\text{WP}}$ must be Low at the same time WPEN is 1. $\overline{\text{WP}}$ may be hardwired to V_{CC} or GND.

HOLD ($\overline{\text{HOLD}}$): This input signal is used to suspend the device in the middle of a serial sequence and temporarily ignore further communication on the bus (SI, SO, SCK). Together with Chip Select, the $\overline{\text{HOLD}}$ signal allows multiple slaves to share the bus. The $\overline{\text{HOLD}}$ signal transitions must occur only when SCK is Low, and be held stable during SCK transitions. (See Figure 8 for Hold timing) To disable this feature, $\overline{\text{HOLD}}$ may be hardwired to V_{CC}.

SERIAL INTERFACE DESCRIPTION

MASTER: The device that provides a clock signal.

SLAVE: The IS25C08/16 is a slave because the clock signal is an input.

TRANSMITTER/RECEIVER: The IS25C08/16 has both data input (SI) and data output (SO).

MSB: The most significant bit. It is always the first bit transmitted or received.

OP-CODE: The first byte transmitted to the slave following CS transition to LOW. If the OP-CODE is a valid member of the IS25C08/16 instruction set (Table 3), then it is decoded appropriately. If the OP-CODE is not valid, and the SO pin remains in high impedance.

BLOCK DIAGRAM

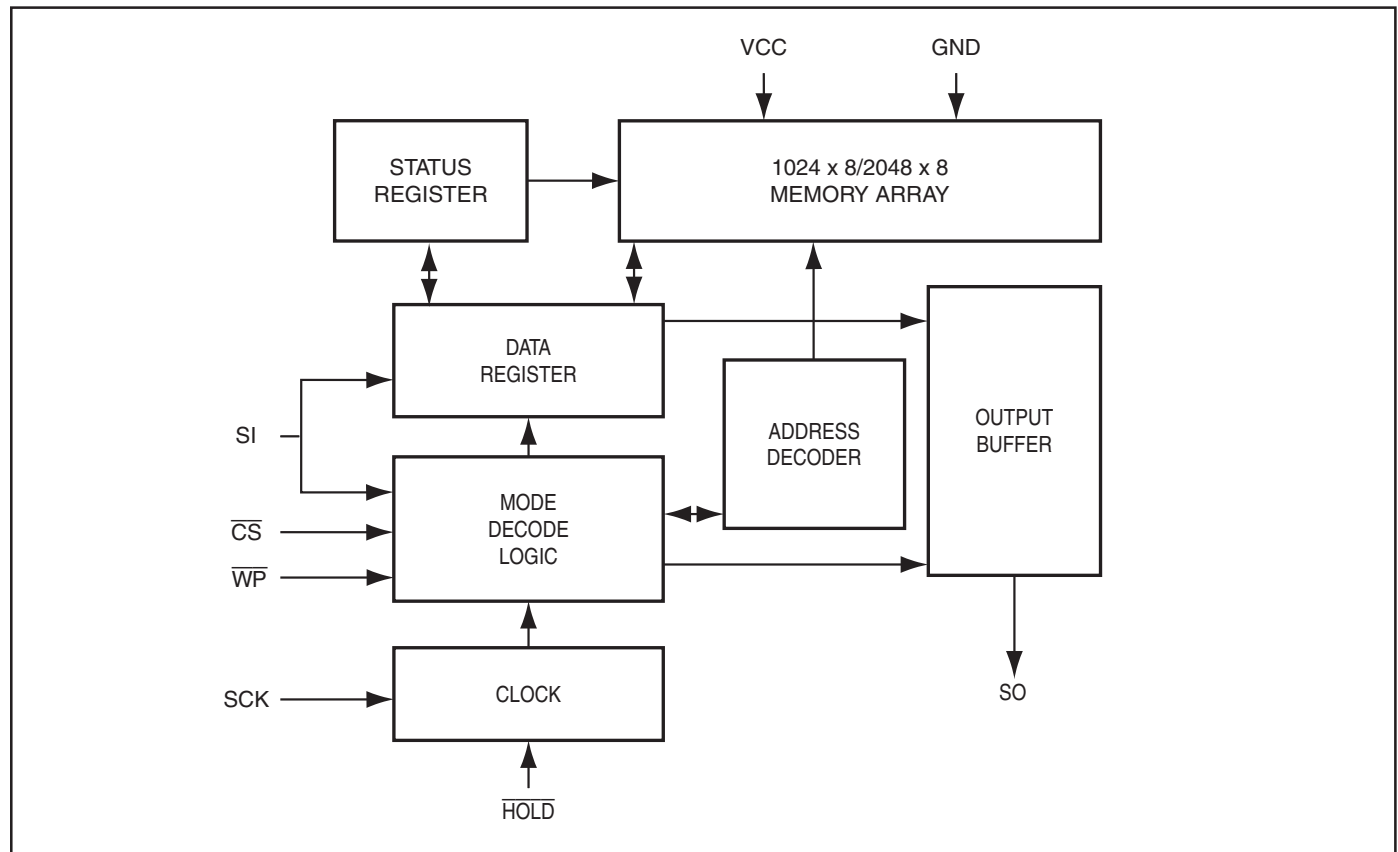

STATUS REGISTER

The status register contains 8-bits for write protection control and write status. (See Table 1). It is the only region of memory other than the main array that is accessible by the user.

Table 1. Status Register Format

Bit 7	Bit 6	Bit 5	Bit 4	Bit 3	Bit 2	Bit 1	Bit 0
WPEN	X	X	X	BP1	BP0	WEN	$\overline{\text{RDY}}$

Notes:

1. X = Don't care bit.
2. During internal write cycles, bits 0 to 7 are temporarily 1's.

The Status Register is Read-Only if either: a) Hardware Write Protection is enabled or b) WEN is set to 0. If neither is true, it can be modified by a valid instruction.

Ready ($\overline{\text{RDY}}$), Bit 0: When $\overline{\text{RDY}} = 1$, it indicates that the device is busy with a write cycle. $\overline{\text{RDY}} = 0$ indicates that the device is ready for an instruction. If $\overline{\text{RDY}} = 1$, the only command that will be handled by the device is Read Status Register.

Write Enable (WEN), Bit 1: This bit represents the status of device write protection. If WEN = 0, the Status Register and the entire array is protected from modification, regardless of the setting of WPEN, $\overline{\text{WP}}$ pin, or block protection. The only way to set WEN to 1 is via the Write Enable command (WREN). WEN is reset to 0 upon power-up.

Block Protect (BP1, BP0), Bits 2-3: Together, these bits represent one of four block protection configurations implemented for the memory array. (See Table 2 for details.)

BP0 and BP1 are non-volatile cells similar to regular array cells, and factory programmed to 0. The block of memory defined by these bits is always protected, regardless of the setting of WPEN, $\overline{\text{WP}}$, or WEN.

Table 2. Block Protection

Level	Status Register Bits		Array Addresses Protected	
	BP1	BP0	IS25C08	IS25C16
0	0	0	None	None
1(1/4)	0	1	0300h -03FFh	0600h -07FFh
2(1/2)	1	0	0200h -03FFh	0400h -07FFh
3(All)	1	1	0000h -03FFh	0000h -07FFh

Don't Care, Bits 4-6: Each of these bits can receive either 0 or 1, but values will not be retained. When these bits are read from the register, they are always 1.

Write Protect Enable (WPEN), Bit 7: This bit can be used in conjunction with $\overline{\text{WP}}$ pin to enable Hardware Write Protection, which causes the Status Register to be read-only. The memory array is not protected by this mode. Hardware Write Protection requires that $\overline{\text{WP}} = 0$ and WPEN = 1; it is disabled otherwise. Note: WPEN cannot be changed from 1 to 0 if the $\overline{\text{WP}}$ pin is already set to Low. (See Table 4 for data protection relationship)

DEVICE OPERATION

The operations of the IS25C08/16 are controlled by a set of instructions that are clocked-in serially SI pin. (See Table 3). To begin an instruction, the chip select (\overline{CS}) should be dropped Low. Subsequently, each Low-to-High transition of the clock (SK) will latch a stable value on the SI pin. After the 8-bit op-code, it may be appropriate to continue to input an address or data to SI, or to output data from SO. During data output, values appear on the falling edge of SK. All bits are transferred with MSB first. Upon the last bit of communication, but prior to any following Low-to-High transition of SK, \overline{CS} should be raised High to end the transaction. The device then would enter Standby Mode if no internal programming were underway.

Table 3. Instruction Set

Name	Op-code	Operation	Address	Data(SI)	Data (SO)
WREN	0000 X110	Set Write Enable Latch	-	-	-
WRDI	0000 X100	Reset Write Enable Latch	-	-	-
RDSR	0000 X101	Read Status Register	-	-	D7-D0,...
WRSR	0000 X001	Write Status Register	-	D7-D0	-
READ	0000 X011	Read Data from Array	A15-A0	-	D7-D0,...
WRITE	0000 X010	Write Data to Array	A15-A0	D7-D0,...	-

1. X = Don't care bit. For consistency, it is best to use "0".
2. Some address bits are don't care. See Table 5.
3. If the bits clocked-in for an op-code are invalid, SO remains high impedance, and upon CS going High there is no affect. A valid op-code with an invalid number of bits clocked-in for address or data will cause an attempt to modify the array or Status Register to be ignored.

WRITE ENABLE (WREN)

When Vcc is initially applied, the device powers up with both status register and entire array in a write-disabled state. Upon completion of Write Disable (WRDI), Write Status Register (WRSR), or Write Data to Array (WRITE), the device resets the WEN bit in the Status Register to 0. Prior to any data modification, a WREN instruction is necessary to set WEN to 1. (See Figure 2 for timing).

WRITE DISABLE (WRDI)

The device can be completely protected from modification by resetting WEN to 0 through the WRDI instruction. (See Figure 3 for timing).

READ STATUS REGISTER (RDSR)

The Read Status instruction tells the user the status of Write Protect Enable, the Block Protection setting (see Table 2), the Write Enable state, and the \overline{RDY} status. RDSR is the only instruction accepted when a write cycle is underway. It is recommended that the status of Write Enable and \overline{RDY} be checked, especially prior to an attempted modification of data. The 8 bits of the Status Register can be repeatedly output on SO after the initial Op-code. (See Figure 4 for timing).

WRITE STATUS REGISTER (WRSR)

This instruction lets the user choose a Block Protection setting, and set or reset the WPEN bit. The values of the other data bits incorporated into WRSR can be 0 or 1, and are not stored in the Status Register. WRSR will be ignored unless both the following are true: a) WEN = 1, due to a prior WREN instruction; and b) Hardware Write Protection is not enabled. (See Table 4 for details). Except for the $\overline{\text{RDY}}$ status, the values in the Status Register remain unchanged until the moment when the write cycle is complete and the register is updated. Note: WPEN can be changed from 1 to 0 only if $\overline{\text{WP}}$ is already set High. Once completed, WEN is reset for complete chip write protection. (See Figure 5 for timing).

READ DATA (READ)

This instruction begins with the op-code and the 16-bit address, and causes the selected data byte to be shifted out on SO. Following this first data byte, additional sequential bytes are output. If the data byte in the highest address is output, the address rolls-over to the lowest address in the array, and the output could loop indefinitely. At any time, a rising $\overline{\text{CS}}$ signal completes the operation. (See Figure 6 for timing).

WRITE DATA (WRITE)

The WRITE instruction begins with the op-code, the 16-bit address of the first byte to be modified, and the first data byte. Additional data bytes may be written sequentially to the array after the first byte. Each WRITE instruction can affect the contents of a 16 byte page, but no more. The page begins at address XXXXXXXX XXXX0000, and ends with XXXXXXXX XXXX1111. If the last byte of the page is input, the address rolls over to the beginning of the same page. More than 16 data bytes can be input during the same instruction, but upon a completed write cycle, a page would only contain the last 16 bytes.

The region of the array defined within Block Protection cannot be modified as long as that block configuration is selected. The region of the array outside the Block Protection can only be modified if Write Enable (WEN) is set to 1. Therefore, it may be necessary that a WREN instruction occur prior to WRITE. Hardware Write Protection has no affect on the memory array. Once Write is completed, WEN is reset for complete chip write protection. (See Figure 7 for timing).

Table 5. Address Key

Name	IS25C08	IS25C16
A_N	A_9-A_0	$A_{10}-A_0$
Don't Care Bits	$A_{15}-A_{10}$	$A_{15}-A_{11}$

Table 4. Write Protection

WPEN	$\overline{\text{WP}}$	Hardware Write Protection	WEN	Inside Block	Outside Block	Status Register (WPEN, BP1, BP0)
0	X	Not Enabled	0	Read-only	Read-only	Read-only
0	X	Not Enabled	1	Read-only	Unprotected	Unprotected
1	0	Enabled	0	Read-only	Read-only	Read-only
1	0	Enabled	1	Read-only	Unprotected	Read-only
X	1	Not Enabled	0	Read-only	Read-only	Read-only
X	1	Not Enabled	1	Read-only	Unprotected	Unprotected

Note: X = Don't care bit.

ABSOLUTE MAXIMUM RATINGS⁽¹⁾

Symbol	Parameter	Value	Unit
V _S	Supply Voltage	-0.5 to + 6.5	V
V _P	Voltage on Any Pin	-0.5 to V _{CC} + 0.5	V
T _{BIAS}	Temperature Under Bias	-55 to +125	°C
T _{STG}	Storage Temperature	-65 to +150	°C
I _{OUT}	Output Current	5	mA

Notes:

1. Stress greater than those listed under ABSOLUTE MAXIMUM RATINGS may cause permanent damage to the device. This is a stress rating only and functional operation of the device at these or any other conditions outside those indicated in the operational sections of this specification is not implied. Exposure to absolute maximum rating conditions for extended periods may affect reliability.

OPERATING RANGE (IS25C16-2 and IS25C08-2)

Range	Ambient Temperature	V _{CC}
Industrial	-40°C to +85°C	1.8V to 5.5V

Note: ISSI offers Industrial grade for Commercial applications (0°C to +70°C).

OPERATING RANGE (IS25C16-3 and IS25C08-3)

Range	Ambient Temperature	V _{CC}
Automotive	-40°C to +125°C	2.5V to 5.5V

CAPACITANCE^(1,2)

Symbol	Parameter	Conditions	Max.	Unit
C _{IN}	Input Capacitance	V _{IN} = 0V	6	pF
C _{OUT}	Output Capacitance	V _{OUT} = 0V	8	pF

Notes:

1. Tested initially and after any design or process changes that may affect these parameters and not 100% tested.
2. Test conditions: T_A = 25°C, f = 1 MHz, V_{CC} = 5.0V.

DC ELECTRICAL CHARACTERISTICS

T_A = -40°C to +85°C for Industrial, T_A = -40°C to +125°C for Automotive.

Symbol	Parameter	Test Conditions	Min.	Max.	Unit
V _{OL1}	Output LOW Voltage	V _{CC} = 5V, I _{OL} = 2 mA	—	0.4	V
V _{OL2}	Output LOW Voltage	V _{CC} = 2.5V, I _{OL} = 1.5 mA	—	0.4	V
V _{OL3}	Output LOW Voltage	V _{CC} = 1.8V, I _{OL} = 0.15 mA	—	0.2	V
V _{OH1}	Output HIGH Voltage	V _{CC} = 5V, I _{OH} = -2 mA	0.8 x V _{CC}	—	V
V _{OH2}	Output HIGH Voltage	V _{CC} = 2.5V, I _{OH} = -0.4mA	0.8 x V _{CC}	—	V
V _{OH3}	Output HIGH Voltage	V _{CC} = 1.8V, I _{OH} = -0.1mA	0.8 x V _{CC}	—	V
V _{IH}	Input HIGH Voltage		0.7xV _{CC}	V _{CC} + 1	V
V _{IL}	Input LOW Voltage		-0.3	0.3 x V _{CC}	V
I _{LI}	Input Leakage Current	V _{IN} = 0V TO V _{CC}	-2	2	μA
I _{LO}	Output Leakage Current	V _{OUT} = 0V TO V _{CC} , \overline{CS} = V _{CC}	-2	2	μA

POWER SUPPLY CHARACTERISTICS - Industrial

T_A = -40°C to +85°C

Symbol	Parameter	Test Conditions	Min.	Max.	Unit
I _{CC1}	Operating Current	Read/Write at 10 MHz (V _{CC} = 5V)	—	5.0	mA
I _{CC2}	Operating Current	Read/Write at 5 MHz (V _{CC} = 2.5V)	—	3.0	mA
I _{CC3}	Operating Current	Read/Write at 2 MHz (V _{CC} = 1.8V)	—	1.0	mA
I _{SB1}	Standby Current	V _{CC} = 5.0V, V _{IN} = V _{CC} or GND \overline{CS} = V _{CC}	—	3.0	μA
I _{SB2}	Standby Current	V _{CC} = 2.5V, V _{IN} = V _{CC} or GND \overline{CS} = V _{CC}	—	2.0	μA
I _{SB3}	Standby Current	V _{CC} = 1.8V, V _{IN} = V _{CC} or GND \overline{CS} = V _{CC}	—	1.0	μA

POWER SUPPLY CHARACTERISTICS - Automotive

T_A = -40°C to +125°C

Symbol	Parameter	Test Conditions	Min.	Max.	Unit
I _{CC1}	Operating Current	Read/Write at 5 MHz (V _{CC} = 5V)	—	4.0	mA
I _{CC2}	Operating Current	Read/Write at 5 MHz (V _{CC} = 2.5V)	—	3.0	mA
I _{SB1}	Standby Current	V _{CC} = 5.0V, V _{IN} = V _{CC} or GND \overline{CS} = V _{CC}	—	8.0	μA
I _{SB2}	Standby Current	V _{CC} = 2.5V, V _{IN} = V _{CC} or GND \overline{CS} = V _{CC}	—	5.0	μA

AC Characteristics - Industrial

T_A = -40°C to +85°C Supply voltage = 1.8V to 5.5V

Symbol	Parameter	1.8V ≤ V _{CC} < 2.5V		2.5V ≤ V _{CC} < 4.5V		4.5V ≤ V _{CC} ≤ 5.5V		Units
		Min	Max	Min	Max	Min	Max	
f _{SCK}	SCK Clock Frequency	0	2	0	5	0	10	MHz
t _{RI}	Input Rise Time	—	2	—	2	—	2	μs
t _{FI}	Input Fall Time	—	2	—	2	—	2	μs
t _{WH}	SCK High Time	200	—	90	—	40	—	ns
t _{WL}	SCK Low Time	200	—	90	—	40	—	ns
t _{CS}	$\overline{\text{CS}}$ High Time	200	—	100	—	40	—	ns
t _{CSS}	$\overline{\text{CS}}$ Setup Time	200	—	90	—	40	—	ns
t _{CSSH}	$\overline{\text{CS}}$ Hold Time	200	—	90	—	25	—	ns
t _{SU}	Data In Setup Time	40	—	20	—	15	—	ns
t _H	Data In Hold Time	50	—	30	—	15	—	ns
t _{HD}	$\overline{\text{Hold}}$ Setup Time	100	—	50	—	25	—	ns
t _{CD}	$\overline{\text{Hold}}$ Hold Time	100	—	50	—	25	—	ns
t _V	Output Valid	0	150	0	60	0	25	ns
t _{HO}	Output Hold Time	0	—	0	—	0	—	ns
t _{LZ}	$\overline{\text{Hold}}$ to Output Low Z	0	100	0	50	0	25	ns
t _{HZ}	$\overline{\text{Hold}}$ to Output High Z	—	250	—	100	—	25	ns
t _{DIS}	Output Disable Time	—	250	—	100	—	25	ns
t _{WC}	Write Cycle Time	—	10	—	5	—	5	ms

Notes:

C_L = 100pF

AC Characteristics - Automotive

T_A = -40°C to +125°C. Supply voltage = 2.5V to 5.5V

Symbol	Parameter	2.5V ≤ V _{CC} < 4.5V		4.5V ≤ V _{CC} ≤ 5.5V		Units
		Min	Max	Min	Max	
f _{SCK}	SCK Clock Frequency	0	5	0	10	MHz
t _{RI}	Input Rise Time	—	2	—	2	μs
t _{FI}	Input Fall Time	—	2	—	2	μs
t _{WH}	SCK High Time	90	—	40	—	ns
t _{WL}	SCK Low Time	90	—	40	—	ns
t _{CS}	$\overline{\text{CS}}$ High Time	100	—	40	—	ns
t _{CSS}	$\overline{\text{CS}}$ Setup Time	90	—	40	—	ns
t _{CSH}	$\overline{\text{CS}}$ Hold Time	90	—	25	—	ns
t _{SU}	Data In Setup Time	20	—	15	—	ns
t _H	Data In Hold Time	30	—	15	—	ns
t _{HD}	$\overline{\text{Hold}}$ Setup Time	50	—	25	—	ns
t _{CD}	$\overline{\text{Hold}}$ Hold Time	50	—	25	—	ns
t _V	Output Valid	0	60	0	25	ns
t _{HO}	Output Hold Time	0	—	0	—	ns
t _{LZ}	$\overline{\text{Hold}}$ to Output Low Z	0	50	0	25	ns
t _{HZ}	$\overline{\text{Hold}}$ to Output High Z	—	100	—	25	ns
t _{DIS}	Output Disable Time	—	100	—	25	ns
t _{WC}	Write Cycle Time	—	5	—	5	ms

Notes:

C_L = 100pF

TIMING DIAGRAMS

Figure 1. Synchronous Data Timing

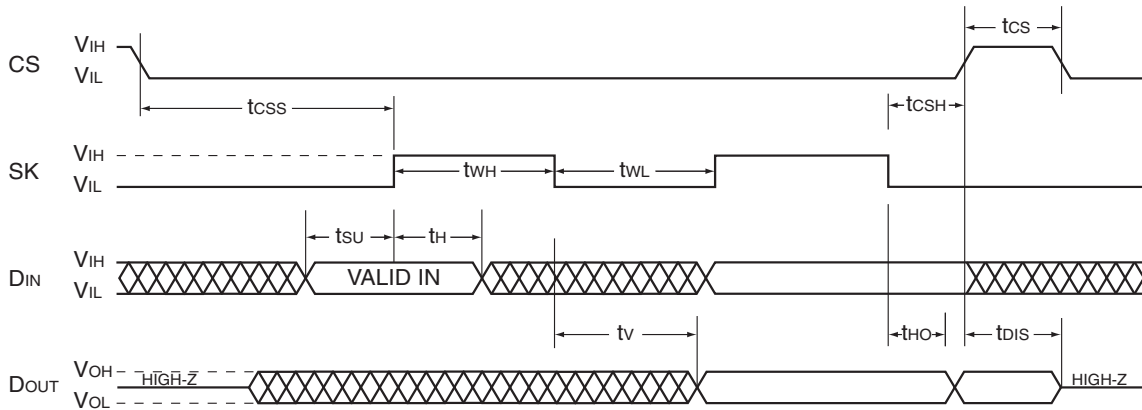

Figure 2. WREN Timing

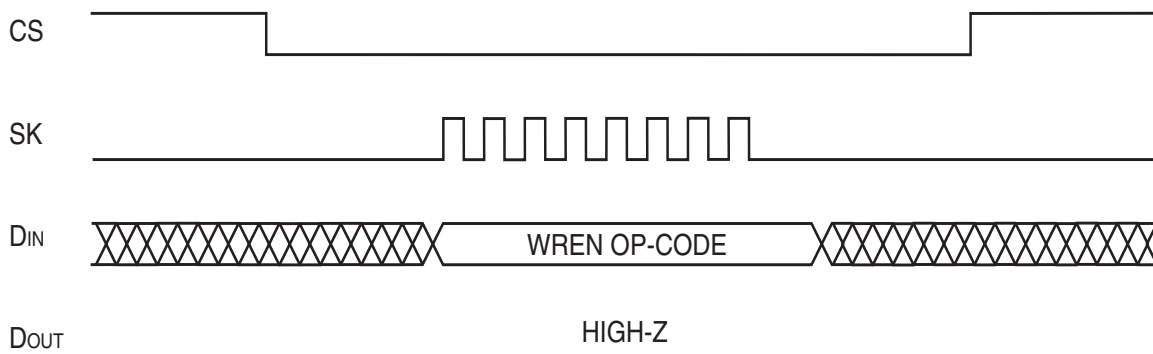

Figure 3. WRDI Timing

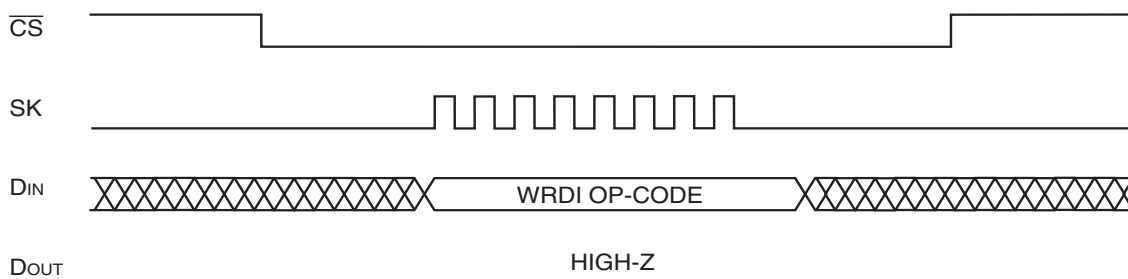

Figure 4. RDSR Timing

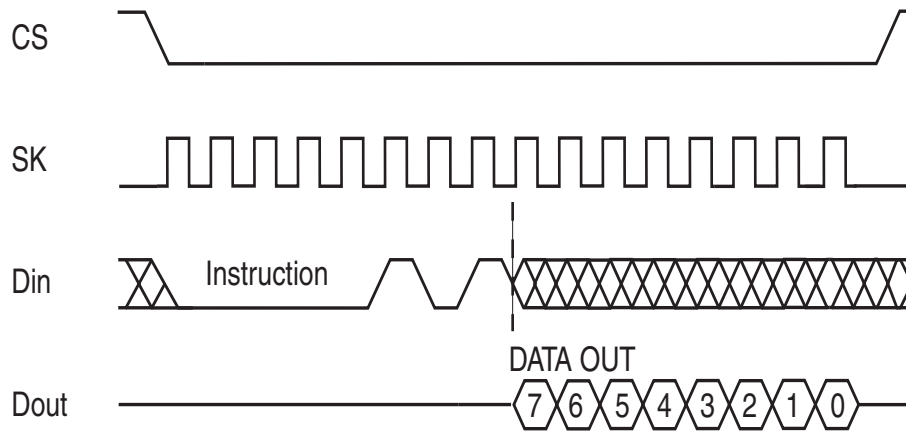

Figure 5. WRSR Timing

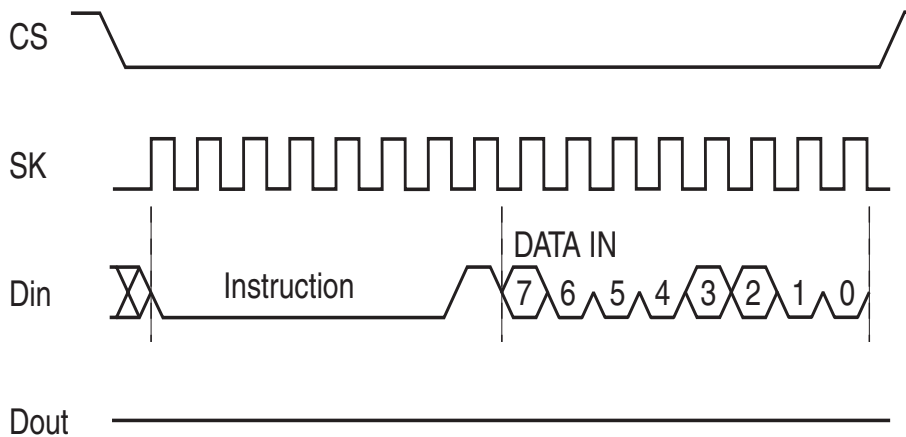

Figure 6. READ Timing

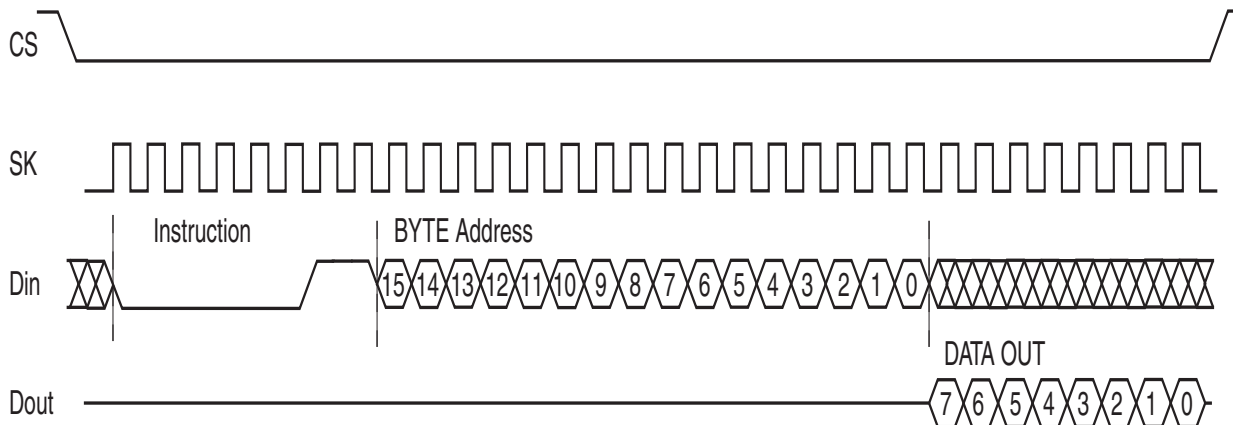

Figure 7. WRITE Timing

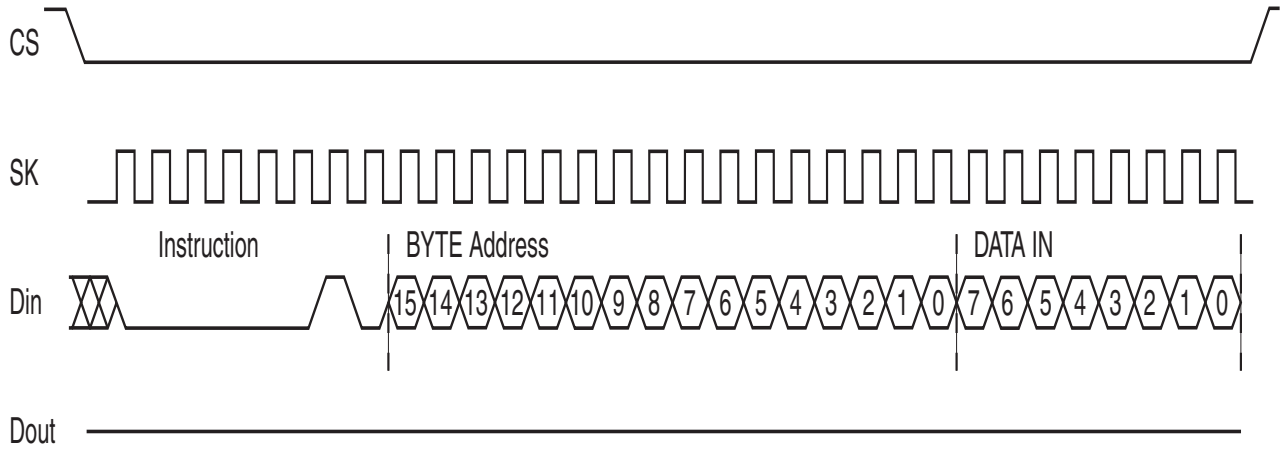
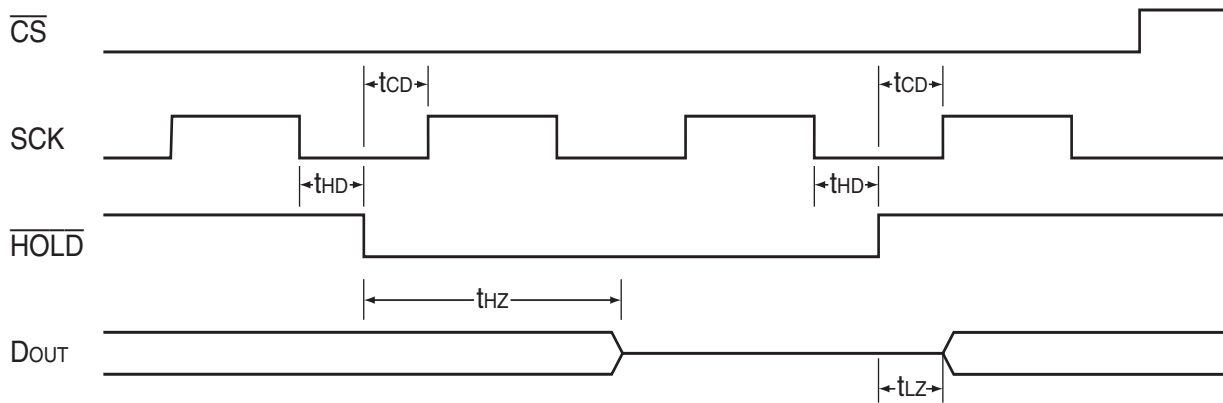

Figure 8. \overline{HOLD} Timing



ORDERING INFORMATION

Industrial Range: -40°C to +85°C, Lead-free

Voltage Range	Part Number	Package
1.8V to 5.5V	IS25C08-2GLI	8-pin 150 mil SOIC (JEDEC STD)
	IS25C08-2ZLI	8-pin 169 mil TSSOP
	IS25C08-2PLI	8-pin 300 mil Plastic DIP
	IS25C08-2DLI	8-pad DFN
	IS25C08-2CLI*	8-ball CSP
1.8V to 5.5V	IS25C16-2GLI	8-pin 150 mil SOIC (JEDEC STD)
	IS25C16-2ZLI	8-pin 169 mil TSSOP
	IS25C16-2PLI	8-pin 300 mil Plastic DIP
	IS25C16-2DLI	8-pad DFN
	IS25C16-2CLI*	8-ball CSP

Industrial Range: -40°C to +85°C

Voltage Range	Part Number	Package
1.8V to 5.5V	IS25C08-2GI*	8-pin 150 mil SOIC (JEDEC STD)
	IS25C08-2ZI*	8-pin 169 mil TSSOP
	IS25C08-2PI*	8-pin 300 mil Plastic DIP
1.8V to 5.5V	IS25C16-2GI*	8-pin 150 mil SOIC (JEDEC STD)
	IS25C16-2ZI*	8-pin 169 mil TSSOP
	IS25C16-2PI*	8-pin 300 mil Plastic DIP

Automotive Range: -40°C to +125°C, Lead-free

Voltage Range	Part Number	Package
2.5V to 5.5V	IS25C08-3GLA3	8-pin 150 mil SOIC (JEDEC STD)
	IS25C08-3ZLA3	8-pin 169 mil TSSOP
	IS25C08-3PLA3	8-pin 300 mil Plastic DIP
2.5V to 5.5V	IS25C16-3GLA3	8-pin 150 mil SOIC (JEDEC STD)
	IS25C16-3ZLA3	8-pin 169 mil TSSOP
	IS25C16-3PLA3	8-pin 300 mil Plastic DIP

*Please contact ISSI Sales Rep for availability.

IS25C08

IS25C16

150-mil Plastic SOP

Package Code: G, GR

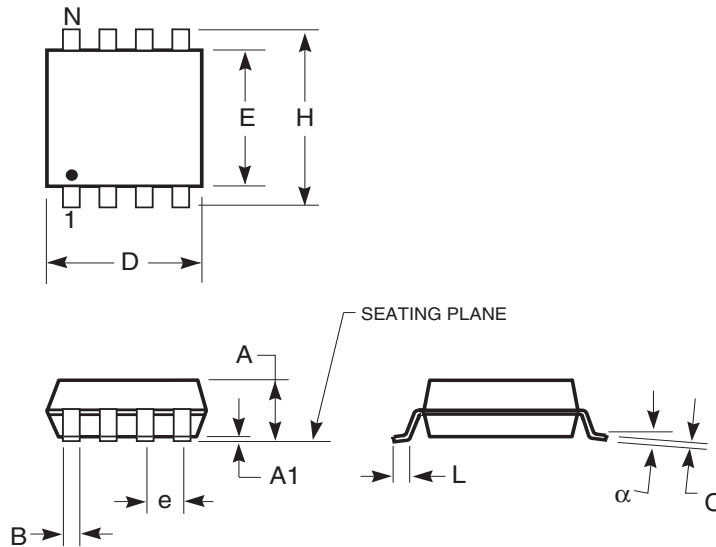

150-mil Plastic SOP (G, GR)

Symbol	Min	Max	Min	Max
Ref. Std.	Inches		mm	
No. Leads	8		8	
A	—	0.068	—	1.73
A1	0.004	0.009	0.1	0.23
B	0.013	0.020	0.33	0.51
C	0.007	0.010	0.18	0.25
D	0.189	0.197	4.8	5
E	0.150	0.157	3.81	3.99
H	0.228	0.245	5.79	6.22
e	0.050 BSC		1.27 BSC	
L	0.020	0.035	0.51	0.89

Notes:

1. Controlling dimension: inches, unless otherwise specified.
2. BSC = Basic lead spacing between centers.
3. Dimensions D and E1 do not include mold flash protrusions and should be measured from the bottom of the package.
4. Formed leads shall be planar with respect to one another within 0.004 inches at the seating plane.

Thin Shrink Small Outline TSSOP
Package Code: Z (8 pin, 14 pin)

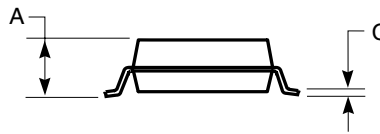
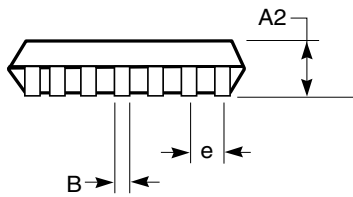
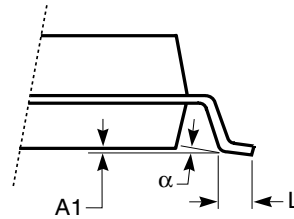
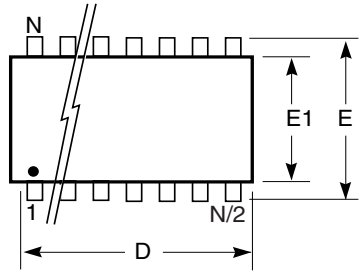

TSSOP (Z)				
Ref. Std.	JEDEC MO-153			
No. Leads	8			
Symbol	Millimeters		Inches	
	Min	Max	Min	Max
A	—	1.20	—	0.047
A1	0.05	0.15	0.002	0.006
A2	0.80	1.05	0.032	0.041
B	0.19	0.30	0.007	0.012
C	0.09	0.20	0.004	0.008
D	2.90	3.10	0.114	0.122
E1	4.30	4.50	0.169	0.177
E	6.40 BSC		0.252 BSC	
e	0.65 BSC		0.026 BSC	
L	0.45	0.75	0.018	0.030
α	—	8°	—	8°

TSSOP (Z)				
Ref. Std.	JEDEC MO-153			
No. Leads	14			
Symbol	Millimeters		Inches	
	Min	Max	Min	Max
A	—	1.20	—	0.047
A1	0.05	0.15	0.002	0.006
A2	0.80	1.05	0.031	0.041
B	0.19	0.30	0.007	0.012
C	0.09	0.20	0.0035	0.008
D	4.90	5.10	0.193	0.201
E1	4.30	4.50	0.170	0.177
E	6.40 BSC		0.252 BSC	
e	0.65 BSC		0.026 BSC	
L	0.45	0.75	0.0177	0.0295
α	—	8°	—	8°

300-mil Plastic DIP
Package Code: N,P

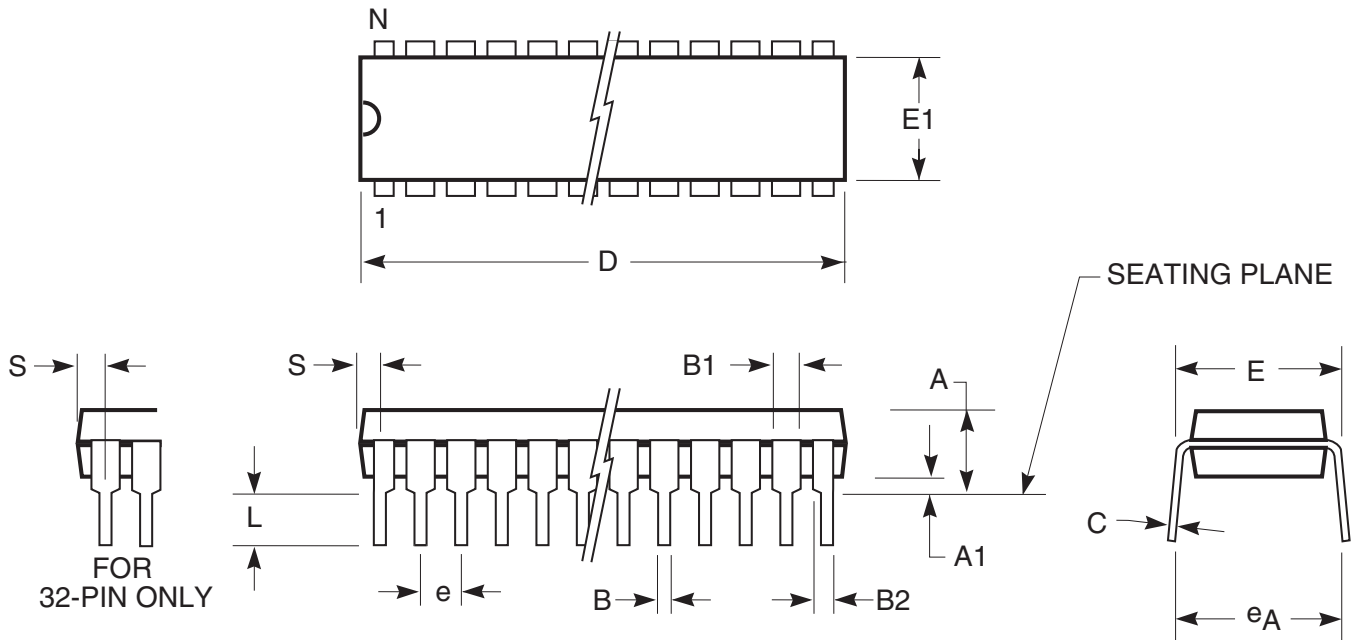

Sym.	MILLIMETERS		INCHES	
	Min.	Max.	Min.	Max.
NO. Leads	8			
A	3.68	4.57	0.145	0.180
A1	0.38	—	0.015	—
B	0.36	0.56	0.014	0.022
B1	1.14	1.52	0.045	0.060
B2	0.81	1.17	0.032	0.046
C	0.20	0.33	0.008	0.013
D	9.12	9.53	0.359	0.375
E	7.62	8.26	0.300	0.325
E1	6.20	6.60	0.244	0.260
e _A	8.13	9.65	0.320	0.380
e	2.54 BSC		0.100 BSC	
L	3.18	—	0.125	—
S	0.64	0.762	0.025	0.030

Notes:

1. Controlling dimension: inches, unless otherwise specified.
2. BSC = Basic lead spacing between centers.
3. Dimensions D and E1 do not include mold flash protrusions and should be measured from the bottom of the package.
4. Formed leads shall be planar with respect to one another within 0.004 inches at the seating plane.

**Dual Flat No-Lead
Package Code: D (8-pad)**

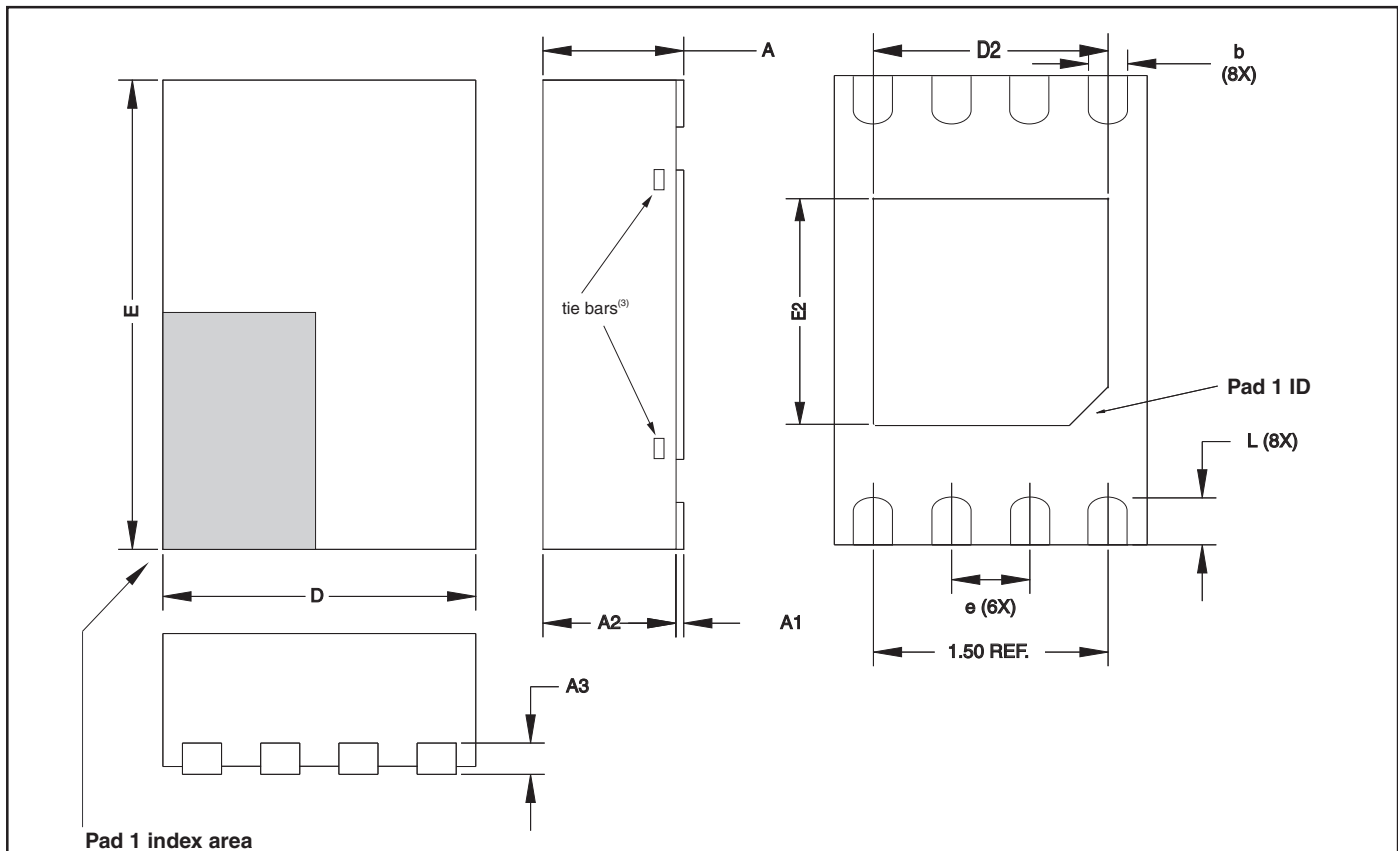

DFN

MILLIMETERS

Sym.	Min.	Nom.	Max.
N0. Pad		8	
D		2.00 BSC	
E		3.00 BSC	
D2	1.50	—	1.75
E2	1.60	—	1.90
A	0.70	0.75	0.80
A1	0.0	0.02	0.05
A2	—	—	0.75
A3		0.20 REF	
L	0.30	0.40	0.50
e		0.50 BSC	
b	0.18	0.25	0.30

Notes:

1. Refer to JEDEC Drawing MO-229.
2. This is the metallized terminal and is measured between 0.18 mm and 0.30 mm from the terminal tip. The terminal may have a straight end instead of rounded.
3. Package may have exposed tie bars, ending flush with package edge.

CSP (i) - Structure of Solder Bump

