

RECOMMENDED P.C. BOARD HOLE LAYOUT

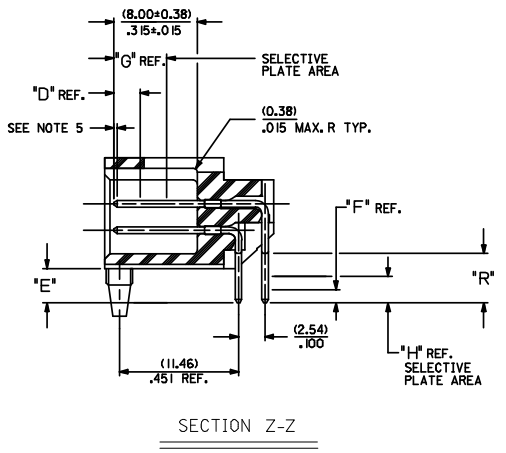
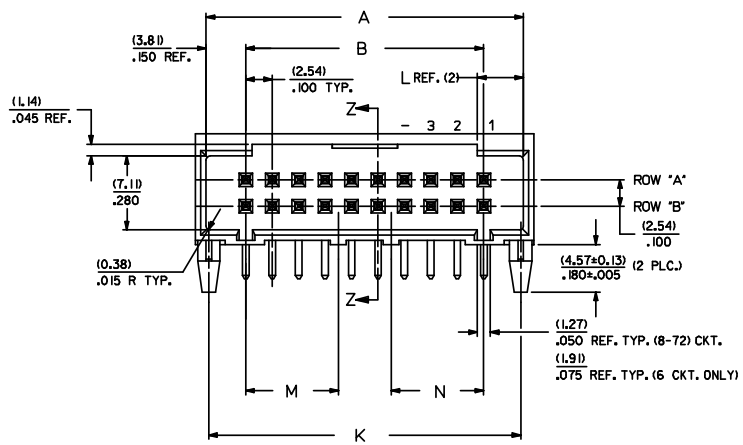

SECTION Z-Z

NOTES:

1. MATERIAL  
SHROUDED WAFER GLASS FILLED NYLON, COLOR BLACK, 94V-0.  
PINS PHOS. BRONZE.
2. FINISH: SEE SHEET 2.
3. THIS PART CONFORMS TO MOLEX PRODUCT SPEC. NO. 70227 AND 70229.
4. PACKAGING INFORMATION. SEE CHARTS ON SHEET 2.
5. 20 CIRCUIT SIZE SHOWN FOR ILLUSTRATION PURPOSES.
6. PIN PUSHOUT FORCE: (17.79 N)/4 LBS.
7. PINS MUST MEET SOLDERABILITY SPEC. MIL-STD-202 METHOD 208B.
8. FOR CHARTED DIMENSIONS AND ASSEMBLY N.O.S NOT SHOWN ON THIS SHEET, SEE SHEET 2.
9. ROW TO ROW PIN HEIGHT VARIATION MUST NOT EXCEED (0.25)/010
10. NO FEATURES WHICH RISE ABOVE THE PCB SURFACE ALLOWED IN THIS AREA.
11. THIS PART CONFORMS TO CLASS B REQUIREMENTS OF COSMETIC SPEC PS-45499-002.

CKT.	DIM. 'A'	DIM. 'B'	DIM. 'K'	DIM. 'L'	DIM. 'M'	DIM. 'N'	DIM. 'P'
06	(12.70) .500	(5.08) .200	(12.19) .480	(3.30) .130			(10.46) .412
08	(15.24) .600	(7.62) .300	(14.73) .580	(4.42) .174			(13.00) .512
10	(17.78) .700	(10.16) .400	(17.27) .680	(4.42) .174			(15.54) .612
12	(20.32) .800	(12.70) .500	(19.81) .780	(4.42) .174			(18.08) .712
14	(22.86) .900	(15.24) .600	(22.35) .880	(4.42) .174			(20.62) .812
16	(25.40) 1.000	(17.78) .700	(24.89) .980	(4.42) .174			(23.16) .912
18	(27.94) 1.100	(20.32) .800	(27.43) 1.080	(4.42) .174			(25.70) 1.012
20	(30.48) 1.200	(22.86) .900	(29.97) 1.180	(4.42) .174			(28.24) 1.112
22	(33.02) 1.300	(25.40) 1.000	(32.51) 1.280	(4.42) .174			(30.78) 1.212
24	(35.56) 1.400	(27.94) 1.100	(35.05) 1.380	(4.42) .174	(16.64) .655		(33.32) 1.312
26	(38.10) 1.500	(30.48) 1.200	(37.59) 1.480	(4.42) .174	(16.64) .655		(35.86) 1.412
28	(40.64) 1.600	(33.02) 1.300	(40.13) 1.580	(4.42) .174	(16.64) .655		(38.40) 1.512
30	(43.18) 1.700	(35.56) 1.400	(42.67) 1.680	(4.42) .174	(16.64) .655		(40.94) 1.612
32	(45.72) 1.800	(38.10) 1.500	(45.21) 1.780	(4.42) .174	(16.64) .655		(43.48) 1.712
34	(48.26) 1.900	(40.64) 1.600	(47.75) 1.880	(4.42) .174	(16.64) .655	(16.76) .660	(46.02) 1.812
36	(50.80) 2.000	(43.18) 1.700	(50.29) 1.980	(4.42) .174	(16.64) .655	(16.76) .660	(48.56) 1.912
38	(53.34) 2.100	(45.72) 1.800	(52.83) 2.080	(4.42) .174	(16.64) .655	(16.76) .660	(51.10) 2.012
40	(55.88) 2.200	(48.26) 1.900	(55.37) 2.180	(4.42) .174	(16.64) .655	(16.76) .660	(53.64) 2.112
42	(58.42) 2.300	(50.80) 2.000	(57.91) 2.280	(4.42) .174	(16.64) .655	(16.76) .660	(56.18) 2.212
44	(60.96) 2.400	(53.34) 2.100	(60.45) 2.380	(4.42) .174	(19.05) .750	(16.76) .660	(58.72) 2.312
46	(63.50) 2.500	(55.88) 2.200	(62.99) 2.480	(4.42) .174	(19.05) .750	(16.76) .660	(61.26) 2.412
48	(66.04) 2.600	(58.42) 2.300	(65.53) 2.580	(4.42) .174	(19.05) .750	(16.76) .660	(63.80) 2.512
50	(68.58) 2.700	(60.96) 2.400	(68.07) 2.680	(4.42) .174	(19.05) .750	(16.76) .660	(66.34) 2.612
52	(71.12) 2.800	(63.50) 2.500	(70.61) 2.780	(4.42) .174	(19.05) .750	(16.76) .660	(68.88) 2.712
54	(73.66) 2.900	(66.04) 2.600	(73.15) 2.880	(4.42) .174	(21.59) .850	(21.84) .860	(71.42) 2.812
56	(76.20) 3.000	(68.58) 2.700	(75.69) 2.980	(4.42) .174	(21.59) .850	(21.84) .860	(73.96) 2.912
58	(78.74) 3.100	(71.12) 2.800	(78.23) 3.080	(4.42) .174	(27.81) 1.095	(26.92) 1.060	(76.50) 3.012
60	(81.28) 3.200	(73.66) 2.900	(80.77) 3.180	(4.42) .174	(27.81) 1.095	(26.92) 1.060	(79.04) 3.112
62	(83.82) 3.300	(76.20) 3.000	(83.31) 3.280	(4.42) .174	(27.81) 1.095	(26.92) 1.060	(81.58) 3.212
64	(86.36) 3.400	(78.74) 3.100	(85.85) 3.380	(4.42) .174	(27.81) 1.095	(26.92) 1.060	(84.12) 3.312
66	(88.90) 3.500	(81.28) 3.200	(88.39) 3.480	(4.42) .174	(27.81) 1.095	(26.92) 1.060	(86.66) 3.412
68	(91.44) 3.600	(83.82) 3.300	(90.93) 3.580	(4.42) .174	(27.81) 1.095	(26.92) 1.060	(89.20) 3.512
70	(93.98) 3.700	(86.36) 3.400	(93.47) 3.680	(4.42) .174	(27.81) 1.095	(26.92) 1.060	(91.74) 3.612
72	(96.52) 3.800	(88.90) 3.500	(96.01) 3.780	(4.42) .174	(27.81) 1.095	(26.92) 1.060	(94.28) 3.712

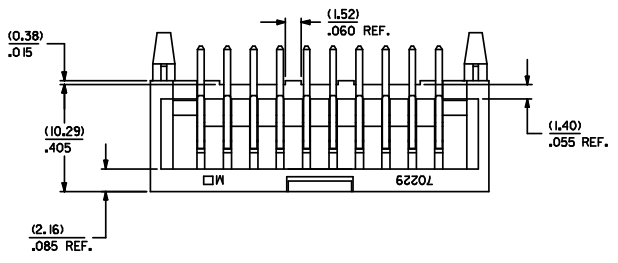
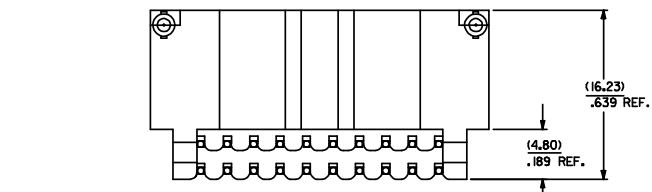

ADD PART NUMBER UCP/2008-3193 DRW/MG/VER/LL CHK/MK/PPR APP/RF/SM/TH 2008/07/01 2008/07/03 2008/07/03	QUALITY SYMBOLS	GENERAL TOLERANCES (UNLESS SPECIFIED)	DIMENSION STYLE	SCALE	DESIGN UNITS	THIRD ANGLE PROJECTION	
	$\nabla=0$ $\nabla=0$	mm INCH 4 PLACES ± --- ± --- 3 PLACES ± --- ± .010 2 PLACES ± 0.25 ± .014 1 PLACE ± 0.36 ± --- ANGULAR ± 1/2°	MM/IN 4:1	INCH	DATE 1986/06/25	TITLE SALES ASSEMBLY RIGHT ANGLE SHROUDED W/PC BOARD STAB. PEGS	SHEET NO. 1 OF 2
	DRAWN BY J L	CHECKED BY R B	DATE 1986/06/25	DATE 1986/06/25	MOLEX MOLEX INCORPORATED	DOCUMENT NO. SDA-70229-XXXX	SHEET NO. 1 OF 2
	DRAFT WHERE APPLICABLE MUST REMAIN WITHIN DIMENSIONS	THIS DRAWING CONTAINS INFORMATION THAT IS PROPRIETARY TO MOLEX INCORPORATED AND SHOULD NOT BE USED WITHOUT WRITTEN PERMISSION					

		20	19	18	17	16	15	14	13	12	11	10	9	8	7	6	5	4	3	2	1
		ENGINEERING PART NUMBER A-70229-		RELEASE FOR MANUFACTURE	E REF.	R REF.	PLATING TYPE	CONNECTOR END PLATING			P.C. BOARD END PLATING			PACKAGING INFORMATION		VOIDED CIRCUITS					
							TYPE	G LENGTH	D MEAS.	TYPE	H LENGTH	F MEAS.	PK-70873-								
M		3001 / 3034	RFM	(3,30) .130	(4,75) .187	15 GOLD	GOLD	(5,08) .200	(2,54) .100	TIN	(2,54) .100	(1,27) .050	0019								
		3035 / 3068	RFM	(3,30) .130	(4,75) .187	TIN	TIN	(2,54) .100	(2,54) .100	TIN	(1,27) .050	(1,27) .050	0019								
L		3069 / 3102	RFM	(3,30) .150	(4,75) .187	50 GOLD	GOLD	(5,08) .200	(2,54) .100	TIN	(2,54) .100	(1,27) .050	0019								
		3103 / 3136	RFM	(3,30) .150	(4,75) .187	30 GOLD	GOLD	(5,08) .200	(2,54) .100	TIN	(2,54) .100	(1,27) .050	0019								
		70229-3341	RFM	(3,30) .130	(4,75) .187	15 GOLD	GOLD	(5,08) .200	(2,54) .100	TIN	(2,54) .100	(1,27) .050	0019		A14, A15, A16, A18, A19, A22, A23 B14, B15, B16, B18, B19, B22, B23						

PLATING:  
TIN .000150 MINIMUM TIN OVER  
.000050 MINIMUM NICKEL PLATE.  
15 GOLD .000015 MINIMUM GOLD PLATE IN SELECTED AREA AND .000075 MINIMUM TIN IN SELECTED AREA OVER .000050 MINIMUM NICKEL OVER-ALL.  
30 GOLD .000030 MINIMUM GOLD PLATE IN SELECTED AREA AND .000075 MINIMUM TIN IN SELECTED AREA OVER .000050 MINIMUM NICKEL OVER-ALL.  
50 GOLD .000050 MINIMUM GOLD PLATE IN SELECTED AREA AND .000075 MINIMUM TIN IN SELECTED AREA OVER .000050 MINIMUM NICKEL OVER-ALL.

\*THE PRIMARY SHIPPING CARTON WILL BE LABELED \*COMPLIANT TO RoHS DIRECTIVE 2002/95/EC AND ELY ANNEX II OF DIRECTIVE 2000/53/EC\*. CARTONS WITHOUT THIS LABEL MAY CONTAIN PRODUCT WITH LEAD.

NO. OF CKTS	15 GOLD		TIN		50 GOLD		30 GOLD													
	EDP NUMBER	ENG NUMBER	EDP NUMBER	ENG NUMBER	EDP NUMBER	ENG NUMBER	EDP NUMBER	ENG NUMBER	EDP NUMBER	ENG NUMBER	EDP NUMBER	ENG NUMBER	EDP NUMBER	ENG NUMBER	EDP NUMBER	ENG NUMBER	EDP NUMBER	ENG NUMBER	EDP NUMBER	ENG NUMBER
06	IS-47-6061	A-70229-3001	IS-47-1061	A-70229-3035	IS-47-1206	A-70229-3069	IS-47-6063	A-70229-3103												
08	IS-47-6081	A-70229-3002	IS-47-1081	A-70229-3036	IS-47-1208	A-70229-3070	IS-47-6083	A-70229-3104												
10	IS-47-6101	A-70229-3003	IS-47-1101	A-70229-3037	IS-47-1210	A-70229-3071	IS-47-6103	A-70229-3105												
12	IS-47-6121	A-70229-3004	IS-47-1121	A-70229-3038	IS-47-1212	A-70229-3072	IS-47-6123	A-70229-3106												
14	IS-47-6141	A-70229-3005	IS-47-1141	A-70229-3039	IS-47-1214	A-70229-3073	IS-47-6143	A-70229-3107												
16	IS-47-6161	A-70229-3006	IS-47-1161	A-70229-3040	IS-47-1216	A-70229-3074	IS-47-6163	A-70229-3108												
18	IS-47-6181	A-70229-3007	IS-47-1181	A-70229-3041	IS-47-1218	A-70229-3075	IS-47-6183	A-70229-3109												
20	IS-47-6201	A-70229-3008	IS-47-1201	A-70229-3042	IS-47-1220	A-70229-3076	IS-47-6203	A-70229-3110												
22	IS-47-6221	A-70229-3009	IS-47-1221	A-70229-3043	IS-47-1222	A-70229-3077	IS-47-6223	A-70229-3111												
24	IS-47-6241	A-70229-3010	IS-47-1241	A-70229-3044	IS-47-1224	A-70229-3078	IS-47-6243	A-70229-3112												
26	IS-47-6261	A-70229-3011	IS-47-1261	A-70229-3045	IS-47-1226	A-70229-3079	IS-47-6263	A-70229-3113												
28	IS-47-6281	A-70229-3012	IS-47-1281	A-70229-3046	IS-47-1228	A-70229-3080	IS-47-6283	A-70229-3114												
30	IS-47-6301	A-70229-3013	IS-47-1301	A-70229-3047	IS-47-1230	A-70229-3081	IS-47-6303	A-70229-3115												
32	IS-47-6321	A-70229-3014	IS-47-1321	A-70229-3048	IS-47-1232	A-70229-3082	IS-47-6323	A-70229-3116												
34	IS-47-6341	A-70229-3015	IS-47-1341	A-70229-3049	IS-47-1234	A-70229-3083	IS-47-6343	A-70229-3117												
36	IS-47-6361	A-70229-3016	IS-47-1361	A-70229-3050	IS-47-1236	A-70229-3084	IS-47-6363	A-70229-3118												
38	IS-47-6381	A-70229-3017	IS-47-1381	A-70229-3051	IS-47-1238	A-70229-3085	IS-47-6383	A-70229-3119												
40	IS-47-6401	A-70229-3018	IS-47-1401	A-70229-3052	IS-47-1240	A-70229-3086	IS-47-6403	A-70229-3120												
42	IS-47-6421	A-70229-3019	IS-47-1421	A-70229-3053	IS-47-1242	A-70229-3087	IS-47-6423	A-70229-3121												
44	IS-47-6441	A-70229-3020	IS-47-1441	A-70229-3054	IS-47-1244	A-70229-3088	IS-47-6443	A-70229-3122												
46	IS-47-6461	A-70229-3021	IS-47-1461	A-70229-3055	IS-47-1246	A-70229-3089	IS-47-6463	A-70229-3123												
48	IS-47-6481	A-70229-3022	IS-47-1481	A-70229-3056	IS-47-1248	A-70229-3090	IS-47-6483	A-70229-3124												
50	IS-47-6501	A-70229-3023	IS-47-1501	A-70229-3057	IS-47-1250	A-70229-3091	IS-47-6503	A-70229-3125												
52	IS-47-6521	A-70229-3024	IS-47-1521	A-70229-3058	IS-47-1252	A-70229-3092	IS-47-6523	A-70229-3126												
54	IS-47-6541	A-70229-3025	IS-47-1541	A-70229-3059	IS-47-1254	A-70229-3093	IS-47-6543	A-70229-3127												
56	IS-47-6561	A-70229-3026	IS-47-1561	A-70229-3060	IS-47-1256	A-70229-3094	IS-47-6563	A-70229-3128												
58	IS-47-6581	A-70229-3027	IS-47-1581	A-70229-3061	IS-47-1258	A-70229-3095	IS-47-6583	A-70229-3129												
60	IS-47-6601	A-70229-3028	IS-47-1601	A-70229-3062	IS-47-1260	A-70229-3096	IS-47-6603	A-70229-3130												
62	IS-47-6621	A-70229-3029	IS-47-1621	A-70229-3063	IS-47-1262	A-70229-3097	IS-47-6623	A-70229-3131												
64	IS-47-6641	A-70229-3030	IS-47-1641	A-70229-3064	IS-47-1264	A-70229-3098	IS-47-6643	A-70229-3132												
66	IS-47-6661	A-70229-3031	IS-47-1661	A-70229-3065	IS-47-1266	A-70229-3099	IS-47-6663	A-70229-3133												
68	IS-47-6681	A-70229-3032	IS-47-1681	A-70229-3066	IS-47-1268	A-70229-3100	IS-47-6683	A-70229-3134												
70	IS-47-6701	A-70229-3033	IS-47-1701	A-70229-3067	IS-47-1270	A-70229-3101	IS-47-6703	A-70229-3135												
72	IS-47-6721	A-70229-3034	IS-47-1721	A-70229-3068	IS-47-1272	A-70229-3102	IS-47-6723	A-70229-3136												

ASSEMBLIES WITH VOIDED CIRCUITS

NO. OF CKTS	15 GOLD		TIN		50 GOLD		30 GOLD	
	EDP NUMBER	ENG NUMBER	EDP NUMBER	ENG NUMBER	EDP NUMBER	ENG NUMBER	EDP NUMBER	ENG NUMBER
50	702293341	70229-3341						

ADD: 70229-3341 EC NO: UCP2008-3199 DRWNGAVERILL 2008/07/01 CHKDKMIPPER 2008/07/03 APPR:FSM/TH 2008/07/03	QUALITY SYMBOLS	GENERAL TOLERANCES (UNLESS SPECIFIED)	DIMENSION STYLE	SCALE	DESIGN UNITS	THIRD ANGLE PROJECTION
	$\nabla=0$ $\nabla=0$	mm INCH 4 PLACES ± --- ± --- 3 PLACES ± --- ± .010 2 PLACES ± 0.25 ± .014 1 PLACE ± 0.36 ± --- ANGULAR ± 1/2°	MM/IN	---	INCH	<input checked="" type="checkbox"/>
	DRAWN BY: J L DATE: 1986/06/25 CHECKED BY: R B DATE: 1986/06/25 APPROVED BY: DATE: 1986/06/25 MATERIAL NO. DOCUMENT NO.	SALES ASSEMBLY RIGHT ANGLE SHROUDED W/PC BOARD STAB. PEGS MOLEX INCORPORATED				
	DRAFT WHERE APPLICABLE MUST REMAIN WITHIN DIMENSIONS	SEE CHART	SDA-70229-****	SHEET NO. 2 OF 2		