

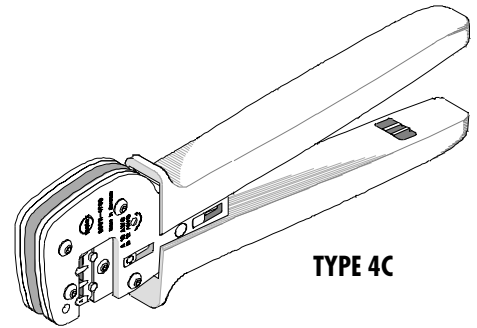

# HAND CRIMP TOOL SPECIFICATION SHEET

Order No. 63811-4700



TYPE 4C

## FEATURES

- A full cycle ratcheting hand tool ensures complete crimps
- Ergonomically designed soft handles
- Precisely designed crimping profiles with simple contact positioning
- Easy handling due to outstanding force ratio

## SCOPE

Products: 10-12 AWG. MLX – 36663/36664

Terminal Series No.	Wire Size		Insulation Diameter		Strip Length	
	AWG	mm <sup>2</sup>	mm	In.	mm	In.
36663/36664*	10-12	5.0-3.3	Note 1	Note 1	6.40-7.14	.252-.281

Note 1: This terminal series does not have an Insulation crimp

## DEFINITION OF TERMS

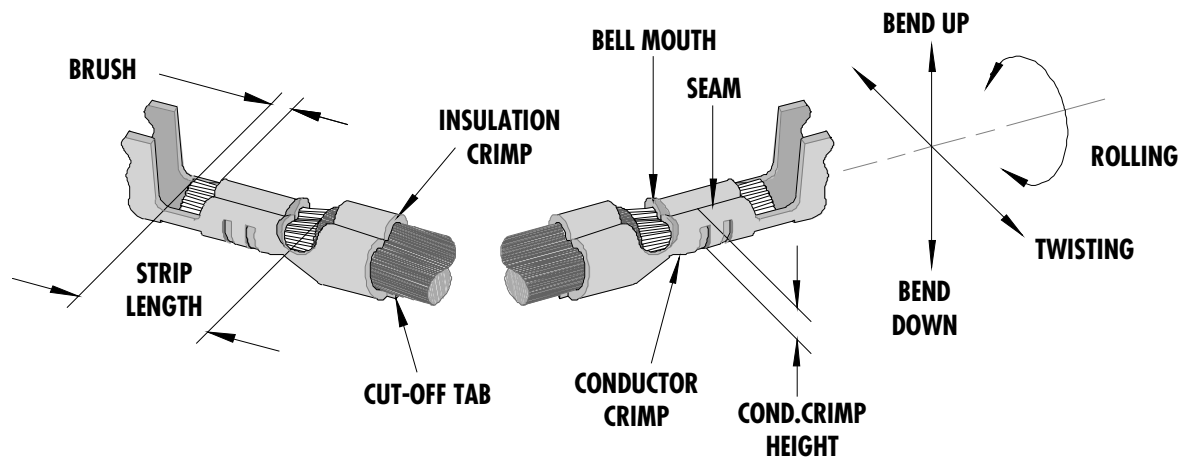

The above terminal drawing is a generic terminal representation. It is not an image of a terminal listed in the scope.

**CONDITIONS:**

After crimping, the conductor profiles should measure the following (See notes on page 4).

Terminal Series No.	Terminal Number	Wire Size		Conductor Crimp Height (REF)		Conductor Crimp Width (Ref)		Pull Force Min.		Profile	
		AWG	mm <sup>2</sup>	mm	In.	mm	In.	N	Lb.	A	B
36663/36664-*	36663/36664-0001	12	3.3	1.90-2.00	.075-.078	3.50-3.60	.138-.142	311.4	70.00		X
36663/36664-*	36663/36664-0002	12	3.3	1.90-2.00	.075-.078	3.50-3.60	.138-.142	311.4	70.00		X
36663/36664-*	36663/36664-0001	10	5.0	2.35-2.45	.093-.095	3.50-3.60	.138-.142	355.9	80.00	X	
36663/36664-*	36663/36664-0002	10	5.0	2.35-2.45	.093-.095	3.50-3.60	.138-.142	355.9	80.00	X	

**OPERATION**

**Caution:** Install only Molex terminals listed above with this tool. Do not crimp hardened objects - damage can occur to the tool or die.

Open the tool by squeezing the handles together, at the end of the closing stroke, the ratchet mechanism will release the handles, and the hand tool will spring open.

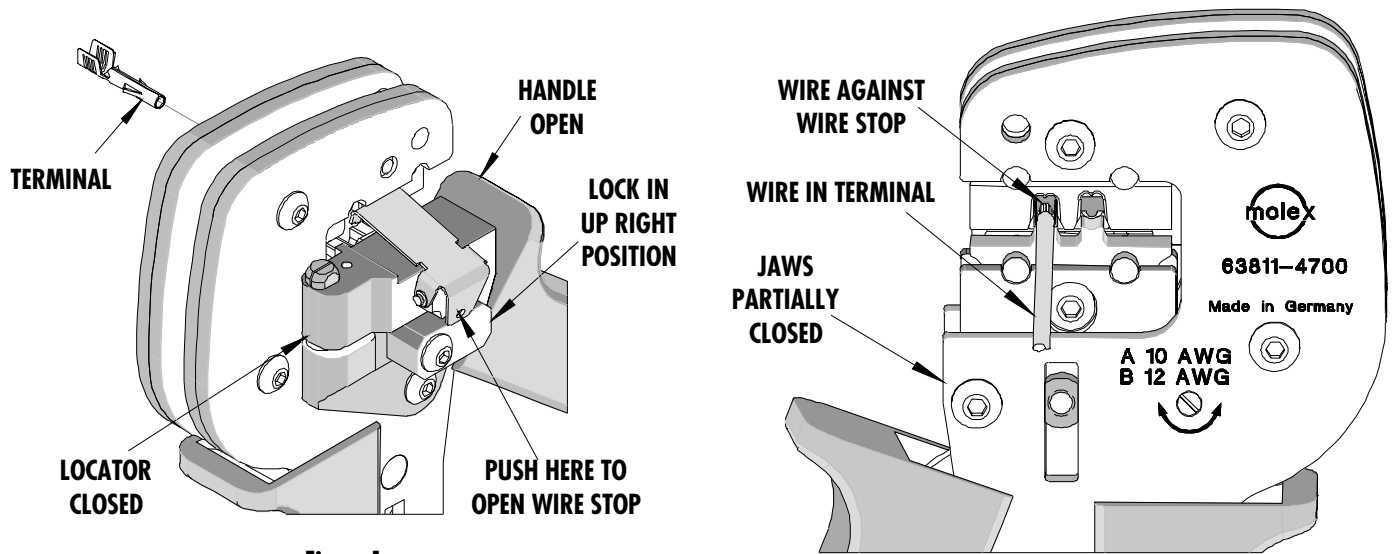

Figure 1

Figure 2

**Crimping Terminals**

Terminals may be loaded when locator is swung open, however when swinging the locator into crimping position, the spring loaded locator needs to be pushed down to clear the tooling. Swing the terminal locator against the crimp tool and turn lock up to lock the locator. Terminals can be loaded easily while locator is up against the crimp tool and locked.

1. Press down on the wire stop on the locator as shown in Figure 2. Insert the proper terminal into the proper nest opening. Make sure when choosing the nest opening, it will correspond with the A or B profile on the hand tool.

2. When the locator is against the crimp tool and locked the terminal is now in proper position for crimping. Partially close the tool until the terminal is held in place.
3. Insert the proper pre-stripped wire over the terminal. Gently touch the wire stop with the end of the wire. See Figure 2 and 3.
4. Compress the terminal by squeezing the tool handles until the ratchet mechanism cycle has been completed. Release handles to open the jaws.

**Note: The tamper proof ratchet action will not release the tool until it has been fully closed.**

5. Remove the crimp terminal from the terminal locator by pressing down on the wire stop and gently pulling on the wire. The terminal locator can be in either position
6. Visually inspect the crimped terminal for proper crimp location and crimp height.

### Maintenance

It is recommended that each operator of the tool be made aware of, and responsible for, the following maintenance steps:

1. Remove dust, moisture, and other contaminants with a clean brush, or soft, lint free cloth.
2. Do not use any abrasive materials that could damage the tool.
3. Make certain all pins; pivot points and bearing surfaces are protected with a thin coat of high quality machine oil. Do not oil excessively.
4. When tool is not in use, keep the handles closed to prevent objects from becoming lodged in the crimping dies, and store the tool in a clean, dry area.

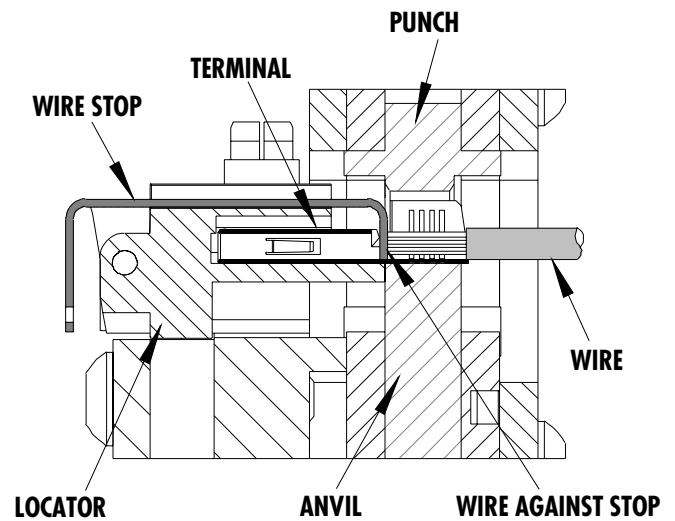

Figure 3

### Miscrimps or Jams (See Figure 4)

Should this tool ever become stuck or jammed in a partially closed position, **Do Not force the handles open or closed.** The tool will open easily by rotating the small slotted screw marked with an arrow. See Figure 4.

### Warranty

This tool is for electrical terminal crimping purposes only. This tool is made of the best quality materials. All vital components are long life tested. All tools are warranted to be free of manufacturing defects for a period of **30 days**. Should such a defect occur, we would exchange the tool free of charge. This will not be applicable to altered, misused, or damaged tools. This tool is designed for hand use only. Any clamping, fixturing, or use of handle extensions voids this warranty.

Hand held crimping tools are intended for low volume, prototyping, or repair requirements only.

**Caution:** Repetitive use of this tool should be avoided.

**Notes:**

1. This tool should only be used for the terminals and wire gauges specified on this sheet.
2. This tool is not adjustable. Variations in tools, terminals, wire stranding and insulation types may affect crimp height. A crimp height chart is provided with this manual as Reference Only.
3. Molex does not repair hand tools (see warranty above). The replacement parts listed are the only parts available for repair. If the handles or crimp tooling is damaged or worn, a new tool must be purchased.
4. An occasional destructive pull force test should be performed to check hand tool crimp. Pull force should be used as the final criteria for an acceptable crimp. Pull force values Must exceed the Minimum pull force specifications listed on pages 2 and 3. Refer to Molex Quality Crimping Handbook 63800-0029 for additional information on crimping and crimp testing.
5. Molex does not certify crimp hand tools.
6. This tool is very difficult to disassemble and reassemble. Customer repair is not recommended.

**CAUTION:** Molex crimp specifications are valid only when used with Molex terminals, applicators and tooling.

**PARTS LIST**

Item Number	Order Number	Description	Quantity
1	63811-4773	Locator Base	1
2	63811-4775	Locator	1

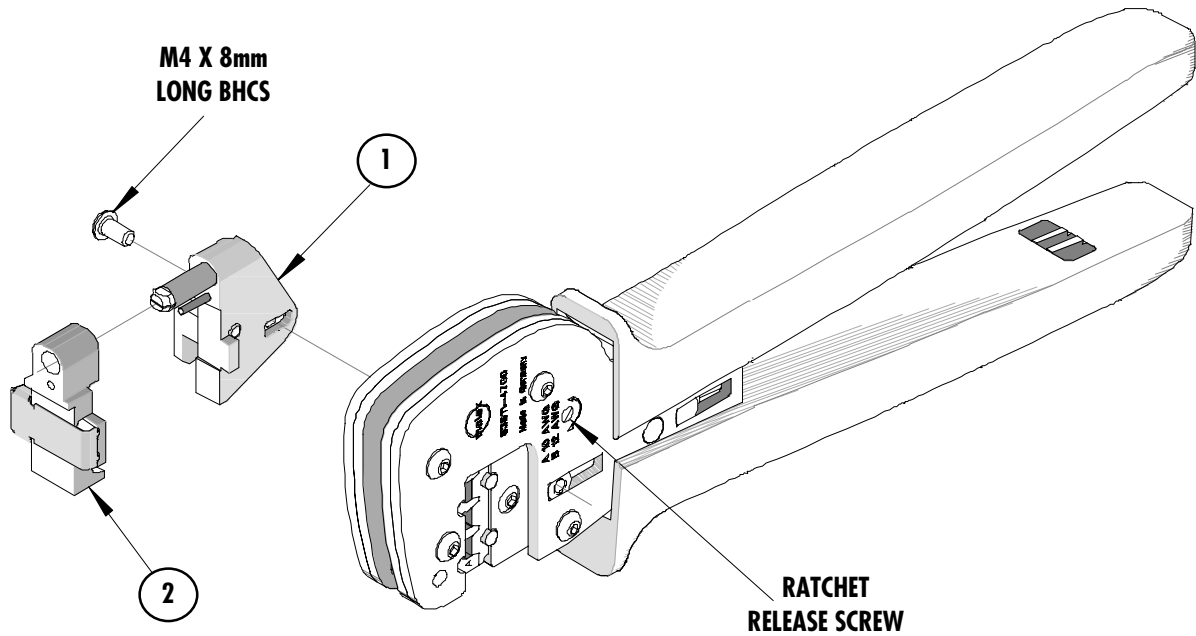

Figure 4

**Molex Application Tooling Group**

1150 E. Diehl Road  
 Naperville, IL, 60563  
 Tel: 630-969-4550  
 Fax: 630-505-0049

Visit our Web site at <http://www.molex.com>