

## STEREO DECODER

### 1 FEATURES

- INTEGRATED 19KHz SC NOTCH FILTER FOR PILOT CANCELLATION
- ON CHIP FILTER FOR PILOT DETECTOR AND PLL
- ADJUSTMENT FREE VOLTAGE CONTROLLED OSCILLATOR
- AUTOMATIC PILOT DEPENDENT MONO/ STEREO SWITCHING
- NOISE BLANKING WITH PROGRAMMABLE THRESHOLD
- HIGH CUT CONTROL AND STEREO BLEND INTEGRATED HIGH PASS FILTER FOR INTERFERENCE DETECTOR
- LEVEL INPUT FOR ADDITIONAL SPIKE DETECTION ON FIELD STRENGTH SIGNAL
- VERY HIGH SUPPRESSION OF HARMONIC AND INTERFERENCE SIGNALS

Figure 1. Package

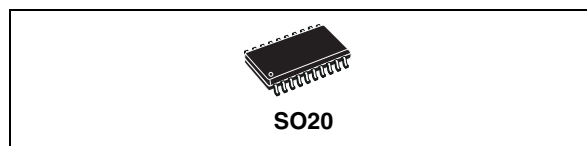

Table 1. Order Codes

Part Number	Package
TDA7338D	SO20
TDA7338D013TR	SO20 in Tape & Reel

### 2 DESCRIPTION

The TDA7338 is a new concept of monolithic integrated stereo decoder with noise blanking for FM car radio applications. With the used BICMOS technique, the 19KHz Notch Filter, the PLL Filter and Phase Filter is realized on the chip with a Switched Capacitor concept. Avoiding the use of multipliers and non linear circuits a very high performance in terms of noise suppression and total harmonic distortion is

Figure 2. reached. Block Diagram

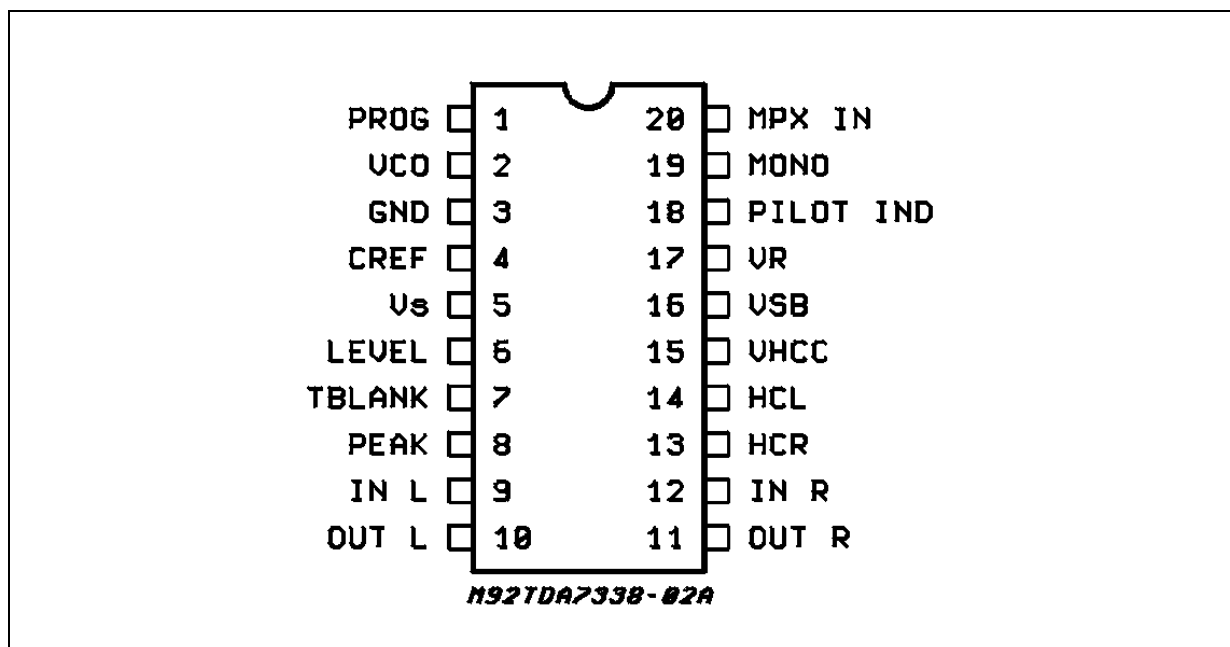

Table 2. Absolute Maximum Ratings

Symbol	Parameter	Value	Unit
V <sub>CC</sub>	DC Supply Voltage	10.5	V
I <sub>CC</sub>	Suply Current	20	mA
T <sub>stg</sub>	Storage Temperature	-55 to 150	°C
T <sub>amb</sub>	Operating AmbientTemperature	-40 to 85	°C

Table 3. Thermal Data

Symbol	Parameter	Value	Unit
R <sub>th j-pins</sub>	Thermal resistance junction-pins	200	°C/W

Figure 3. Block Diagram and Test Circuit

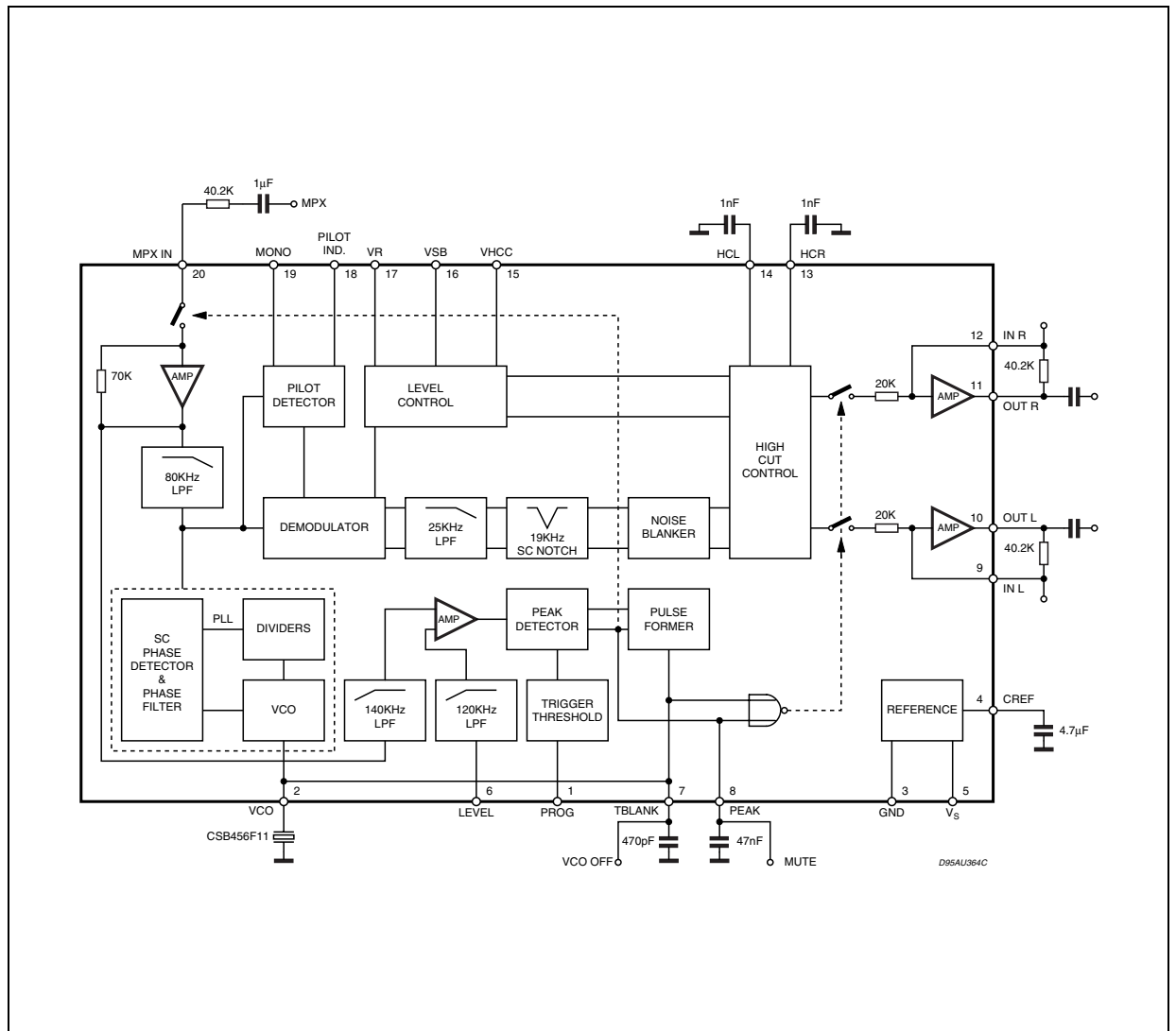

### 3 ELECTRICAL CHARACTERISTICS

**Table 4.**

( $V_{CC} = 9V$ ; modulation frequency: 1KHz; de-emphasis time:  $T = 50\mu s$ ; nominal MPX input voltage:  $V_{MPX} = 1.5V_{PP}$ ; m 100% (75KHz deviation,  $f_{mod} = 1KHz$ );  $R_{IN} = 40.2k\Omega$ ,  $R_{OUT} = 40.2k\Omega$ ;  $T_{amb} = 27^{\circ}C$ ;  $C_{REF} = 4.7\mu F$ ; unless otherwise specified)

Symbol	Parameter	Test Condition	Min.	Typ.	Max.	Unit
$V_{CC}$	Supply Voltage		7.5	9	10.2	V
$I_{CC}$	Supply Current		5	10	15	mA
$V_{IN}$	MPX Input Level (peak to peak)	$f_m = 1KHz$		1.5		V
$V_{ORMS}$	A.F. Output Voltage (mono)	pin 10 and 11 $V_{IN} = 0.5V_{RMS}$ MONO;		1.5		V
SVRR	Supply Voltage Ripple Rejection	$V_{RIPPLE} = 200mV$ ; $f = 1KHz$	40	55		dB
$V_L/V_R$	Difference of Output Voltage Levels	pin 10 and 11- mono	-0.8		0.8	dB
$V_o/V_i$	Gain	$V_{10}/V_{20}$	8.5	9.5	10.5	dB
$R_O$	Output Resistance	pin 10 and 11		10	50	$\Omega$
$V_O$	DC Output Voltage	pin 10 and 11	4.2	4.5	4.8	V
$\alpha$	Channel Separation	$V_R - V_{SB} = -50mV_{DC}$	30	45		dB
THD	Total Harmonic Distortion			0.02	0.3	%
$\frac{S+N}{N}$	Signal plus noise to noise ratio	$f = 20Hz$ to 16KHz; $S = 2V_{rms}$		91		dB
$\alpha_M$	Muting Attenuation	$V_7$ and $V_8 < 0.6V$		100		dB
$V_{DC}$	Mute DC Steps at pins 10, 11	Mute at pin 8		0	4	mV
<b>CARRIER AND HARMONIC SUPPRESSION AT THE OUTPUT</b>						
$\alpha_{19}$	Pilot Signal $f = 19KHz$		55	70		dB
$\alpha_{38}$	Subcarrier $f = 38KHz$			75		dB
$\alpha_{57}$	Subcarrier $f = 57KHz$			62		dB
$\alpha_{76}$	Subcarrier $f = 76KHz$			90		dB
<b>INTERMODULATION (note 1)</b>						
$\alpha_2$	$f_{mod} = 10KHz$ ; $f_{spur} = 1KHz$			65		dB
$\alpha_3$	$f_{mod} = 13KHz$ ; $f_{spur} = 1KHz$			75		dB
<b>TRAFFIC RADIO (note 2)</b>						
$\alpha_{57}$	Signal $f = 57KHz$			70		dB
<b>SCA - SUBSIDIARY COMMUNICATIONS AUTHORIZATION (note 3)</b>						
$\alpha_{67}$	Signal $f = 67KHz$			75		dB
<b>ACI - ADJACENT CHANNEL INTERFERENCE (note4)</b>						
$\alpha_{114}$	Signal $f = 114KHz$			95		dB
$\alpha_{190}$	Signal $f = 190KHz$			84		dB
<b>MONO/ STEREO SWITCH</b>						
$V_{INTH}$	Pilot Threshold Voltage	for stereo "ON"	12	20	28	$mV_{RMS}$
$V_{INTH}$	Pilot Threshold Voltage	for stereo "OFF"	7	14	21	$mV_{RMS}$
$V_{PI}$	Pilot Indicator Saturation Voltage	$I = 1mA$		0.2	0.5	V
$I_{PI}$	Pilot Indicator Leakage Current	$V = 9V$			10	$\mu A$
$V_{19}$	Control Voltage for forced mono	$\alpha = < 3dB$			0.8	V

**Table 4.**

(V<sub>CC</sub> = 9V; modulation frequency: 1KHz; de-emphasis time: T = 50μs; nominal MPX input voltage: V<sub>MPX</sub> = 1.5V<sub>PP</sub>; m 100% (75KHz deviation, f<sub>mod</sub> = 1KHz); R<sub>IN</sub> = 40.2kΩ, R<sub>OUT</sub> = 40.2kΩ; T<sub>amb</sub> = 27°C; C<sub>REF</sub> = 4.7μF; unless otherwise specified)

<b>STEREO BLEND</b>						
V <sub>16-17</sub>	Control Voltage for Channel Separation	α = 6dB; V <sub>R</sub> = 3.6V (note 5)	-0.31	-0.27	-0.23	V
V <sub>16-17</sub>	Control Voltage for Channel Separation	α = 26dB;	-85	-55	-30	mV
<b>HIGH CUT CONTROL</b>						
τ <sub>deemp</sub>	De-Emphasis Time Constant	C <sub>13</sub> , C <sub>14</sub> = 1nF; V <sub>15-17</sub> = 50mV	43	50	57	μs
R <sub>15-17</sub>	High Cut Control Resistance	V <sub>15 - 17</sub> = 50mV	43	50	57	KΩ
R <sub>15-17</sub>	High Cut Control Resistance	V <sub>15 - 17</sub> = -0.5V (note 5)	115	150	185	KΩ
<b>VCO</b>						
f <sub>osc</sub>	Oscillator Frequency	with Murata CSB456F11		456		KHz
Δf/f	Capture and Holding Range			±1		%
V <sub>VCO</sub>	V <sub>CO OFF</sub>	Pin 7			0.6	V
<b>NOISE INTERFACE DETECTOR</b> (test condition: V <sub>SB</sub> > V <sub>R</sub> + 50mV)						
V <sub>TR</sub>	Trigger Threshold (note 6)	V <sub>PEAK</sub> = 1.3V; PROG = GND		180		mV
		V <sub>PEAK</sub> = 1.3V; PROG = OPEN/V <sub>DD</sub>		250		mV
V <sub>TR</sub>	Trigger Threshold	V <sub>PEAK</sub> = 1.5V; PROG = GND		260		mV
		V <sub>PEAK</sub> = 1.5V; PROG = OPEN/V <sub>DD</sub>		340		mV
T <sub>S</sub>	Suppression Pulse Duration	C <sub>BLANK</sub> = 470pF		50		μs
I <sub>OS</sub>	Input Offset Current during suppression time			10		pA
V <sub>N1</sub>	V <sub>PEAK</sub> (pin 8)	V <sub>IN</sub> = 0mV <sub>RMS</sub>	0.7	1.0	1.3	V
V <sub>N2</sub>	V <sub>PEAK</sub> (pin 8)	V <sub>IN</sub> = 50mV <sub>RMS</sub> ; f = 150KHz	1.1	1.5	2	V
V <sub>N3</sub>	V <sub>PEAK</sub> (pin 8)	V <sub>IN</sub> = 100mV <sub>RMS</sub> ; f = 150KHz	1.7	2.3	2.8	V

**3.1 NOTES TO THE CHARACTERISTICS**

1) INTERMODULATION SUPPRESSION

$$\alpha_2 = \frac{V_O(\text{signal})(\text{at}1\text{KHz})}{V_O(\text{spurious})(\text{at}1\text{KHz})} ; f_s = (2 \times 10\text{KHz}) - 19\text{KHz}$$

$$\alpha_3 = \frac{V_O(\text{signal})(\text{at}1\text{KHz})}{V_O(\text{spurious})(\text{at}1\text{KHz})} ; f_s = (3 \times 13\text{KHz}) - 38\text{KHz}$$

measured with : 91% mono signal; 9% pilot signal; fm=10KHz or 13KHz

2) TRAFFIC RADIO (V.F.) suppression

$$\alpha_{57(V.W.F.)} = \frac{V_O(\text{signal})(\text{at}1\text{KHz})}{V_O(\text{spurious})(\text{at}1\text{KHz} \pm 23\text{KHz})}$$

measured with : 91% stereo signal; 9% pilot signal; fm=1KHz; 5% subcarrier (f = 57KHz, fm = 23Hz AM, m = 60%)

### 3. SCA (SUBSIDIARY COMMUNICATIONS AUTHORIZATION)

$$\alpha_{67} = \frac{V_O(\text{signal})(\text{at}1\text{KHz})}{V_O(\text{spurious})(\text{at}9\text{KHz})} ; f_s = (2 \times 38\text{KHz}) - 67\text{KHz}$$

measured with : 81% mono signal; 9% pilot signal;  $f_m=1\text{KHz}$ ;  
10% SCA - subcarrier ( $f_s = 67\text{KHz}$ , unmodulated)

### 4. ACI (ADJACENT CHANNEL INTERFERENCE)

$$\alpha_{114} = \frac{V_O(\text{signal})(\text{at}1\text{KHz})}{V_O(\text{spurious})(\text{at}4\text{KHz})} ; f_s = 110\text{KHz} - (3 \times 38\text{KHz})$$

$$\alpha_{190} = \frac{V_O(\text{signal})(\text{at}1\text{KHz})}{V_O(\text{spurious})(\text{at}4\text{KHz})} ; f_s = 186\text{KHz} - (5 \times 38\text{KHz})$$

measured with : 90% mono signal; 9% pilot signal;  $f_m=1\text{KHz}$ ; 1% spurious signal  
( $f_s = 110\text{KHz}$  or  $186\text{KHz}$ , unmodulated)

5. Control range typ 11% of VR (see figure 5 and figure 6)

### 6. MEASUREMENT OF TRIGGER THRESHOLDS

All thresholds are measured by using a pulse with  $T_R = 2\mu\text{s}$ ,  $T_{\text{HIGH}} = 2\mu\text{s}$ , and  $T_F = 10\mu\text{s}$ . The repetition rate must not increase the PEAK voltage.

Figure 4.

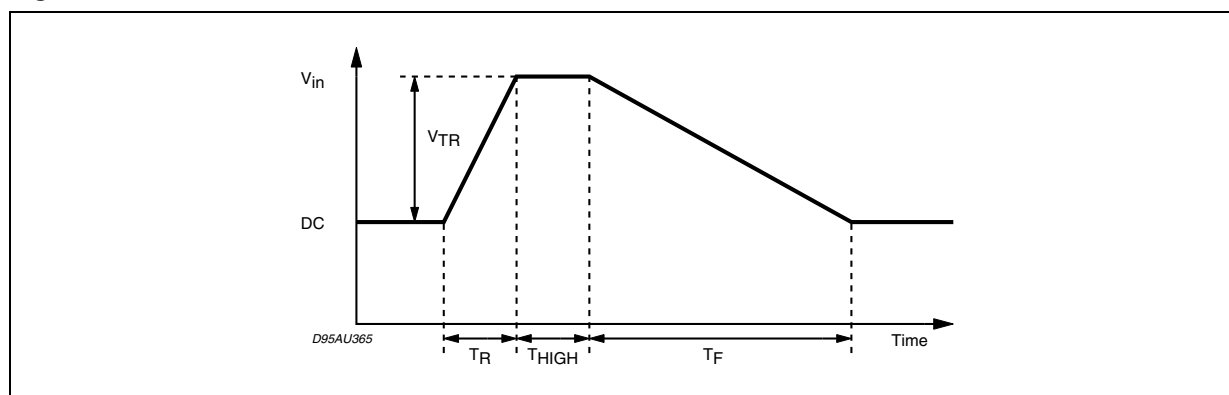

## 4 FUNCTIONAL DESCRIPTION

### 4.1 Signal Path

The TDA7338 Stereodecoder contains all necessary functions for processing the MPX signal. Due to the external input resistance (Pin 20) the circuit can be adapted to different MPX input levels. Behind a 80kHz lowpass filter the adjustment free PLL for the pilot Tone is placed.

The only external component needed for the PLL is the ceramic resonator for the oscillator which runs at 456kHz.

The pilot detector output is designed as an open collector output, therefore an external pullup resistor is needed. To force the decoder to "MONO" Pin 19 has to be clamped to a voltage below 0.8V.

The voltage level (signal strength from the IF part) applied to Pin 15 (VHCC) allows to control the time constant of the deemphasis (nom. =  $50\mu\text{s}$ , see fig. 5). If the RF-signal is weak, the corner frequency is reduced down to 1kHz to improve the signal to noise ratio.

Figure 5. High Cut Control

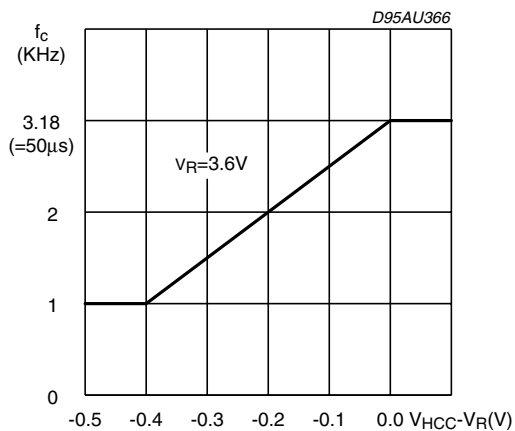
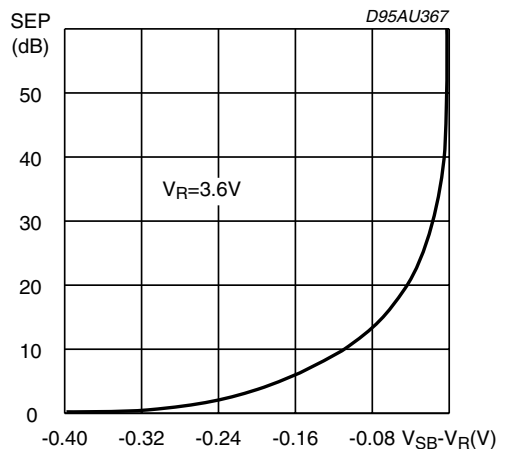

Figure 6. Stereo Blend



Furthermore the conditions of the stereo separation (see fig.6) can be controlled through the signal applied to Pin 16 (VSB). Both signal levels (VSB and VHCC) are referred to Pin 17 (VR), with the characteristic that the control range is 11% of VR. By modifying the feedback resistor value of the output stages (Pin 9 - 10, Pin 11 - 12) the total gain of the stereodecoder can be modified.

Pin 7 and Pin 8 have an additional function. By pulling them to ground the VCO-OFF (Pin 7) and the MUTE (Pin 8) function are activated. The MUTE signal disconnects the MPX-signal from the circuit, while in combination with VCO-OFF also the output buffers are disconnected from the circuit. In this mode the output buffers can be used for AM-stereo, cassette play back and other purposes.

#### 4.2 AM Mono Mode

By selecting VCO-OFF (Pin 7 to GND) the VCO is switched off and the SB and HCC are disabled. The deemphasis time constant is changed to  $40\mu\text{s}$  ( $f_c = 4\text{KHz}$ ).

#### 4.3 DESCRIPTION OF THE NOISE BLANKER

In the normal automotive environment the MPX signal is disturbed by ignition spikes, motors and high frequency switches etc.

The aim of the noise blanker part is to cancel the influence of the spikes produced by these components. Therefore the output of the stereodecoder is switched off for a time of  $40\mu\text{s}$  (average spike duration).

In a first stage the spikes must be detected but to avoid a wrong triggering on high frequency noise a complex trigger control is implemented. Behind the trigger stage a pulse former generates the 40ms "blanking" pulse. This duration of  $40\mu\text{s}$  can be varied by changing the capacitor at pin 7.

##### 4.3.1 Trigger Path

The incoming MPX signal is highpass-filtered, amplified and rectified (block RECT-PEAK). The second order highpass-filter has a corner-frequency of 140KHz.

The rectifier signal, RECT, is used to generate by peak-rectification a signal called PEAK, which is available at the PEAK pin 8.

Also noise with a frequency  $>100\text{KHz}$  increases the PEAK voltage. The value of the PEAK voltage influences the trigger threshold voltage  $V_{th}$  (block ATC). The higher the noise level the higher the threshold.

Both signals, RECT and PEAK+ $V_{th}$  are fed to a comparator (block PEAK-COMP) which outputs a saw-tooth-shaped waveform at the TBLANK pin 7. A second comparator (block BLANK-COMP) forms the internal blanking duration of  $40\mu\text{s}$ . The noise blanker is supplied by his own biasing circuit (block BIAS-MONO) to avoid any cross talk to the signal path (block BIAS-MONO).

### 4.3.2 Noise Controlled Threshold Adjustment (ATC)

The behaviour of the noise controlled threshold adjustment is shown in fig. 8. It can be influenced lightly by adding a resistor in parallel to the PEAK capacitor at Pin 8 either to GND or VDD. A resistor to GND will decrease the threshold whereas a resistor to VDD will increase it. But it is recommended to choose one of the internal thresholds by use of the PROG pin (see table 5)

### 4.3.3 Automatic Threshold Control by the Stereoblend voltage (ATC-SB)

Besides the noise controlled threshold adjustment there is an additional possibility for influencing the trigger. It is controlled by the difference between  $V_{sb}$  and  $V_r$ , similar to the Stereoblend. The reason for implementing such a second control will be explained in the following: The point where the MPX signal starts to become noisy is fixed by the RF part. Therefore also the starting point of the normal noise controlled trigger adjustment is fixed (fig.9). But in some cases the behaviour of the noiseblanker can be improved by increasing the threshold even in a region of higher fieldstrength, for the MPX signal often shows distortion in this range, which leads to an undesired triggering.

Because of the overlap of this range and the range of the stereo/mono transition it can be controlled by  $V_{sb}$  and  $V_r$ . This threshold increase is programmable (see fig. 9).

### 4.3.4 Blend Mode

Another possibility to avoid a disturbing triggering on modulation is to use the spikes on the fieldstrength signal (LEVEL pin). But in the range of higher fieldstrength the signal saturates and no more spike detection is possible. For this reason the TDA7338 offers the "BLEND MODE". When "BLEND MODE" is activated a smooth transition between the LEVEL- and the MPX-signal is used to detect the spikes either on LEVEL or on MPX.

In the lower fieldstrength range mainly the LEVEL-signal is used whereas in the higher range mainly the MPX is used.

This switching is controlled also by the normal Stereoblend signal to avoid additional pins. "BLEND MODE OFF" is activated by connecting the LEVEL pin to GND (LEVEL must be also connected to GND if not used).

Figure 7. Block Diagram of the Noise Blanker

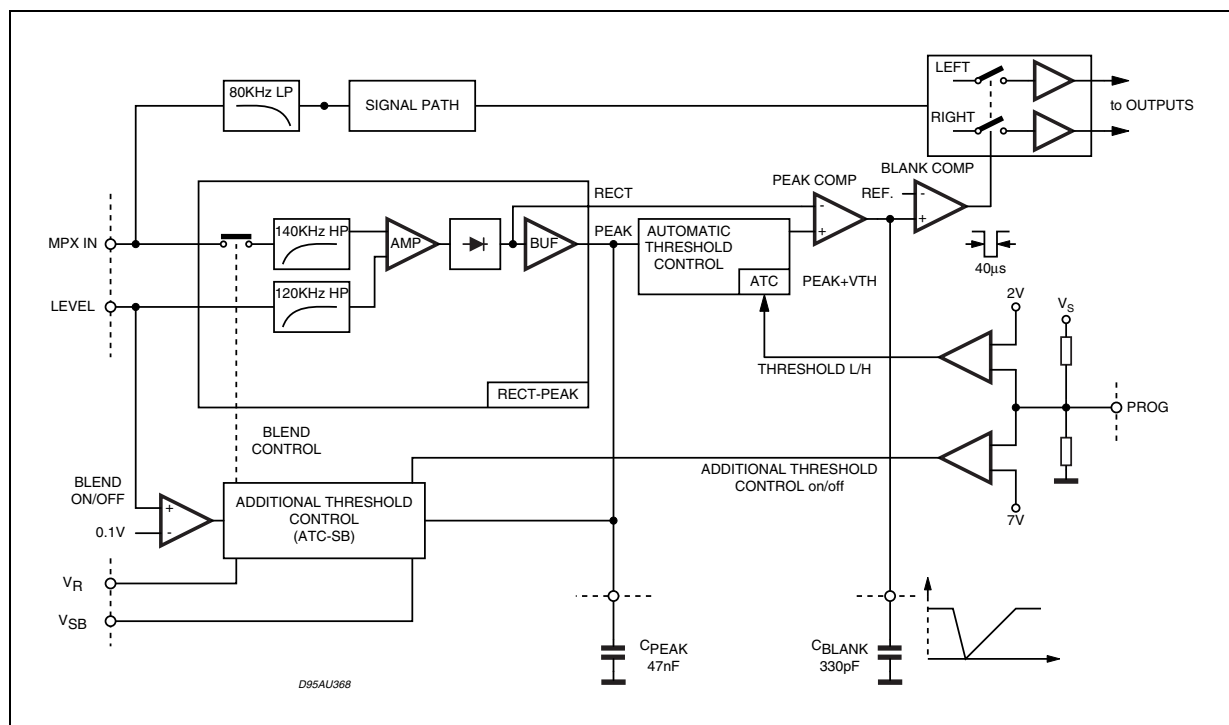

Table 5. Programming of the Noiseblanker

PIN 1 (PROG)	Trigger Threshold	Peak Voltage Control By Fieldstrength
GND	LOW	ON
OPEN	HIGH	ON
V <sub>DD</sub>	HIGH	OFF

Figure 8. Trigger Threshold vs. V<sub>PEAK</sub>

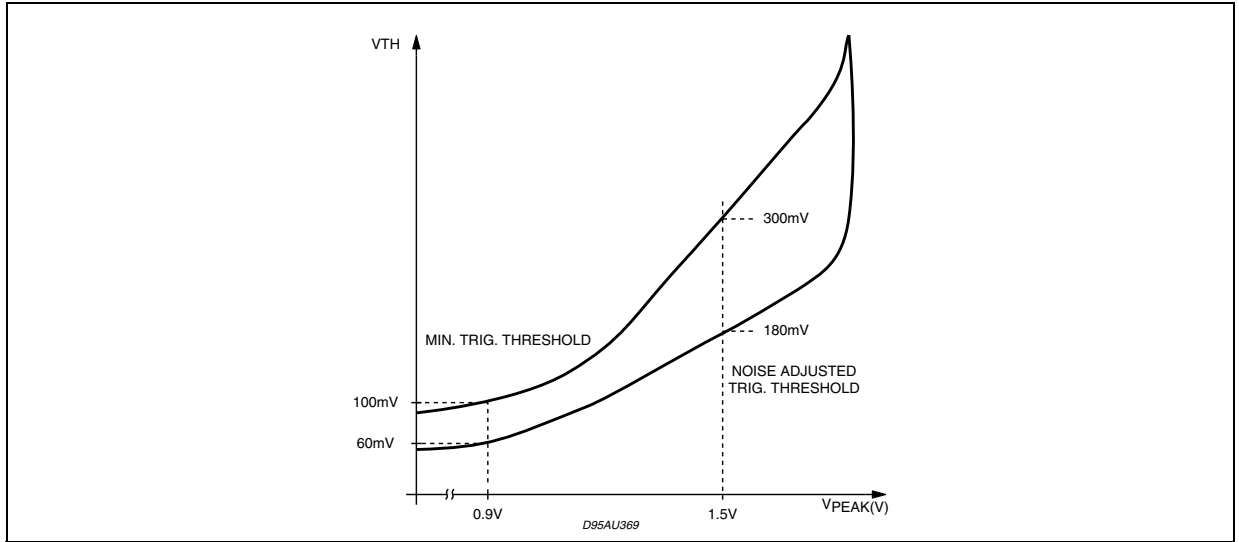

Figure 9. Behaviour of the Field Strength Controlled Threshold Adjustment

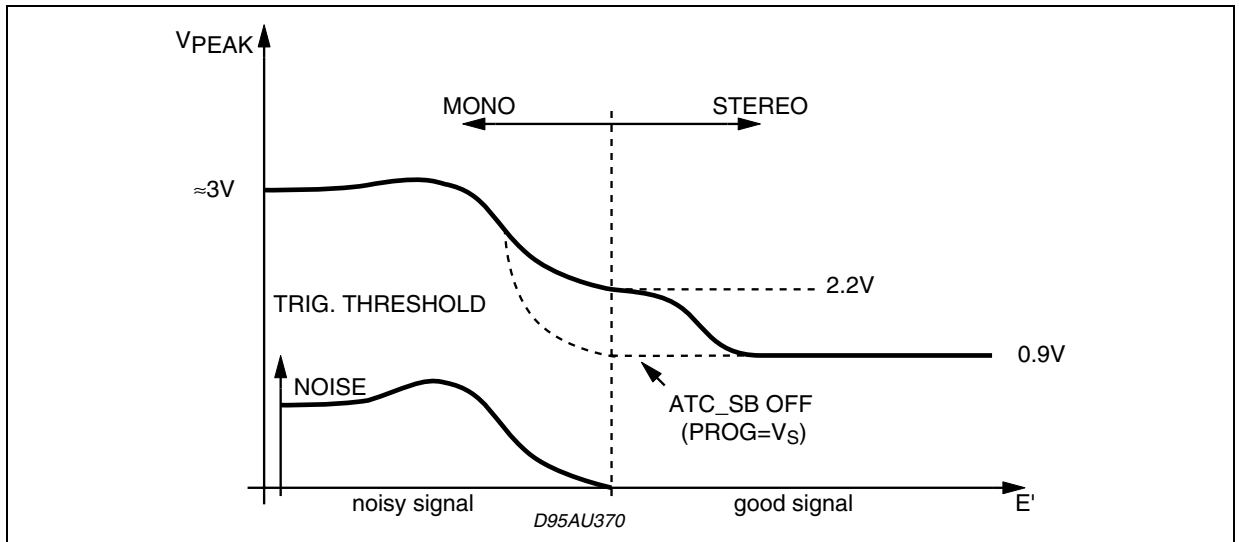



Figure 10. Application Diagram

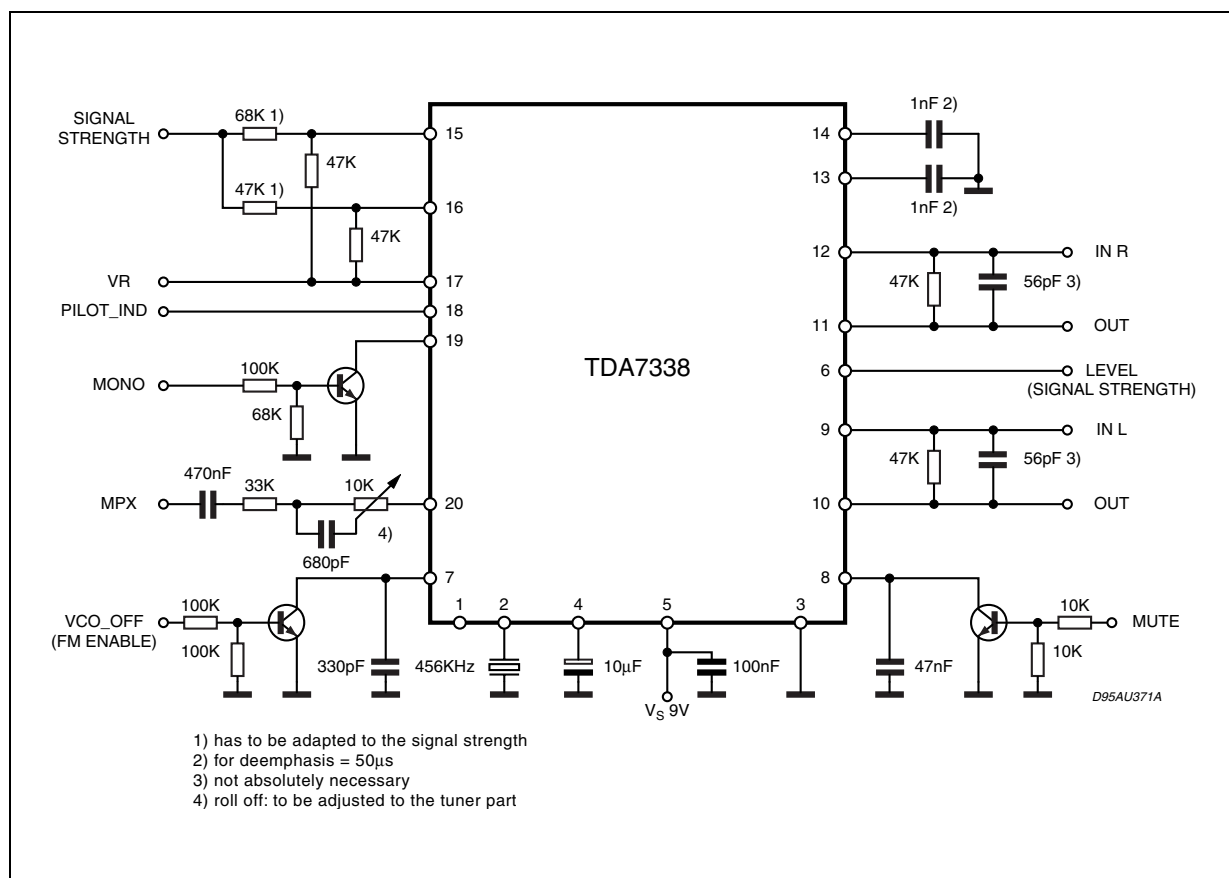
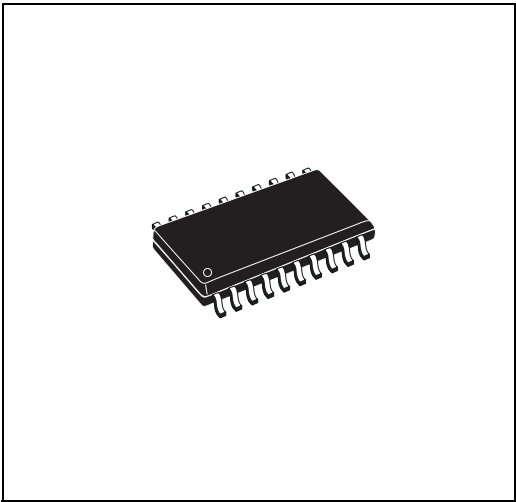

Figure 11. SO20 Mechanical Data & Package Dimensions

DIM.	mm			inch		
	MIN.	TYP.	MAX.	MIN.	TYP.	MAX.
A	2.35		2.65	0.093		0.104
A1	0.10		0.30	0.004		0.012
B	0.33		0.51	0.013		0.200
C	0.23		0.32	0.009		0.013
D (1)	12.60		13.00	0.496		0.512
E	7.40		7.60	0.291		0.299
e		1.27			0.050	
H	10.0		10.65	0.394		0.419
h	0.25		0.75	0.010		0.030
L	0.40		1.27	0.016		0.050
k	0° (min.), 8° (max.)					
ddd			0.10			0.004

(1) "D" dimension does not include mold flash, protusions or gate burrs. Mold flash, protusions or gate burrs shall not exceed 0.15mm per side.

**OUTLINE AND MECHANICAL DATA**



**SO20**

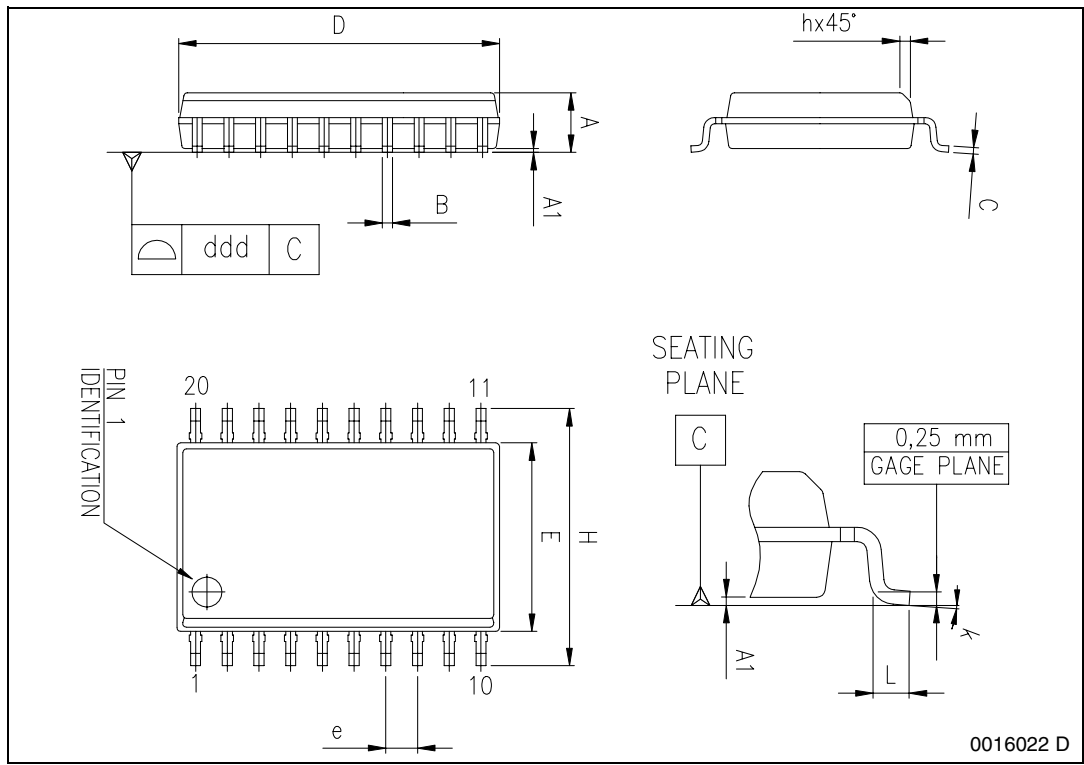

0016022 D

## 5 REVISION HISTORY

**Table 6. Revision History**

Date	Revision	Description of Changes
October 2004	8	First Issue in EDOCS
April 2005	9	Changed the Style-sheet in compliance to the new "Corporate Technical Publications Design Guide. Deleted DIP20 Package

Information furnished is believed to be accurate and reliable. However, STMicroelectronics assumes no responsibility for the consequences of use of such information nor for any infringement of patents or other rights of third parties which may result from its use. No license is granted by implication or otherwise under any patent or patent rights of STMicroelectronics. Specifications mentioned in this publication are subject to change without notice. This publication supersedes and replaces all information previously supplied. STMicroelectronics products are not authorized for use as critical components in life support devices or systems without express written approval of STMicroelectronics.

The ST logo is a registered trademark of STMicroelectronics.  
All other names are the property of their respective owners

© 2005 STMicroelectronics - All rights reserved

STMicroelectronics group of companies

Australia - Belgium - Brazil - Canada - China - Czech Republic - Finland - France - Germany - Hong Kong - India - Israel - Italy - Japan -  
Malaysia - Malta - Morocco - Singapore - Spain - Sweden - Switzerland - United Kingdom - United States of America

[www.st.com](http://www.st.com)